

USB-1608GX

Multifunction DAQ Device

User's Guide

Your new Measurement Computing product comes with a fantastic extra —

Management committed to your satisfaction!

Thank you for choosing a Measurement Computing product—and congratulations! You own the finest, and you can now enjoy the protection of the most comprehensive warranties and unmatched phone tech support. It's the embodiment of our mission:

- To provide data acquisition hardware and software that will save time and save money.

Simple installations minimize the time between setting up your system and actually making measurements. We offer quick and simple access to outstanding live FREE technical support to help integrate MCC products into a DAQ system.

Limited Lifetime Warranty: Most MCC products are covered by a limited lifetime warranty against defects in materials or workmanship for the life of the product, to the original purchaser, unless otherwise noted. Any products found to be defective in material or workmanship will be repaired, replaced with same or similar device, or refunded at MCC's discretion. For specific information, please refer to the terms and conditions of sale.

Harsh Environment Program: Any Measurement Computing product that is damaged due to misuse, or any reason, may be eligible for replacement with the same or similar device for 50% of the current list price. I/O boards face some harsh environments, some harsher than the boards are designed to withstand. Contact MCC to determine your product's eligibility for this program.

30 Day Money-Back Guarantee: Any Measurement Computing Corporation product may be returned within 30 days of purchase for a full refund of the price paid for the product being returned. If you are not satisfied, or chose the wrong product by mistake, you do not have to keep it.

These warranties are in lieu of all other warranties, expressed or implied, including any implied warranty of merchantability or fitness for a particular application. The remedies provided herein are the buyer's sole and exclusive remedies. Neither Measurement Computing Corporation, nor its employees shall be liable for any direct or indirect, special, incidental or consequential damage arising from the use of its products, even if Measurement Computing Corporation has been notified in advance of the possibility of such damages.

Trademark and Copyright Information

Measurement Computing Corporation, InstaCal, Universal Library, and the Measurement Computing logo are either trademarks or registered trademarks of Measurement Computing Corporation. Refer to the Copyrights & Trademarks section on mccdaq.com/legal for more information about Measurement Computing trademarks. Other product and company names mentioned herein are trademarks or trade names of their respective companies.

© 2014 Measurement Computing Corporation. All rights reserved. No part of this publication may be reproduced, stored in a retrieval system, or transmitted, in any form by any means, electronic, mechanical, by photocopying, recording, or otherwise without the prior written permission of Measurement Computing Corporation.

Notice

Measurement Computing Corporation does not authorize any Measurement Computing Corporation product for use in life support systems and/or devices without prior written consent from Measurement Computing Corporation. Life support devices/systems are devices or systems that, a) are intended for surgical implantation into the body, or b) support or sustain life and whose failure to perform can be reasonably expected to result in injury. Measurement Computing Corporation products are not designed with the components required, and are not subject to the testing required to ensure a level of reliability suitable for the treatment and diagnosis of people.

Table of Contents

Preface	
About this User's Guide	5
What you will learn from this user's guide	5
Conventions in this user's guide	5
Where to find more information	5
Chapter 1	
Introducing the USB-1608GX.....	6
Functional block diagram	6
Chapter 2	
Installing the USB-1608GX.....	7
Unpacking.....	7
Installing the software	7
Installing the hardware	7
Calibrating	7
Self-calibration	7
Factory calibration	7
Firmware updates	7
Chapter 3	
Functional Details	8
Analog input modes.....	8
Software paced.....	8
Hardware paced	8
Burst mode.....	8
External components	9
USB connector.....	9
LEDs.....	9
Screw terminals.....	9
Signal connections.....	11
Analog input	11
External clock I/O.....	12
Digital I/O.....	12
Trigger input.....	13
Counter input	13
Timer output	14
Power output.....	14
Ground.....	14
Mechanical drawings.....	15
Chapter 4	
Specifications	16
Analog input	16
Accuracy.....	17
Analog input DC voltage measurement accuracy	17
Noise performance.....	17
Settling time.....	17
Analog input calibration	17
Digital input/output.....	18
External trigger.....	18
External clock input/output.....	19
Counter	19

Timer	20
Memory	20
Power	20
USB	20
Environmental	21
Mechanical	21
Screw terminal connector	21
Differential mode pinout	21
Single-ended mode pinout	22
Declaration of Conformity	23

About this User's Guide

What you will learn from this user's guide

This user's guide describes the Measurement Computing USB-1608GX data acquisition device and lists device specifications.

Conventions in this user's guide

For more information

Text presented in a box signifies additional information and helpful hints related to the subject matter you are reading.

Caution! Shaded caution statements present information to help you avoid injuring yourself and others, damaging your hardware, or losing your data.

bold text **Bold** text is used for the names of objects on a screen, such as buttons, text boxes, and check boxes.

italic text *Italic* text is used for the names of manuals and help topic titles, and to emphasize a word or phrase.

Where to find more information

Additional information about the USB-1608GX is available on our website at www.mccdaq.com. You can also contact Measurement Computing Corporation by phone, fax, or email with specific questions.

- Knowledgebase: kb.mccdaq.com
- Tech support form: www.mccdaq.com/support/support_form.aspx
- Email: techsupport@mccdaq.com
- Phone: 508-946-5100 and follow the instructions for reaching Tech Support

For international customers, contact your local distributor. Refer to the International Distributors section on our website at www.mccdaq.com/International.

Introducing the USB-1608GX

The USB-1608GX is a USB 2.0 high-speed device that provides the following features:

- 16 single-ended (SE) or eight differential (DIFF) analog input channels
- Eight individually configurable digital I/O channels
- Two counter channels (32-bit) that count TTL pulses
- One timer output channel (32-bit)
- Screw terminals for field wiring connections

The USB-1608GX is powered by the +5 volt USB supply from your computer; no external power is required. A USB cable is shipped with the device.

The USB-1608GX device is compatible with both USB 1.1 and USB 2.0 ports. The speed of the device may be limited when using a USB 1.1 port due to the difference in transfer rates on the USB 1.1 versions of the protocol (low-speed and full-speed).

Functional block diagram

USB-1608GX functions are illustrated in the block diagram shown here.

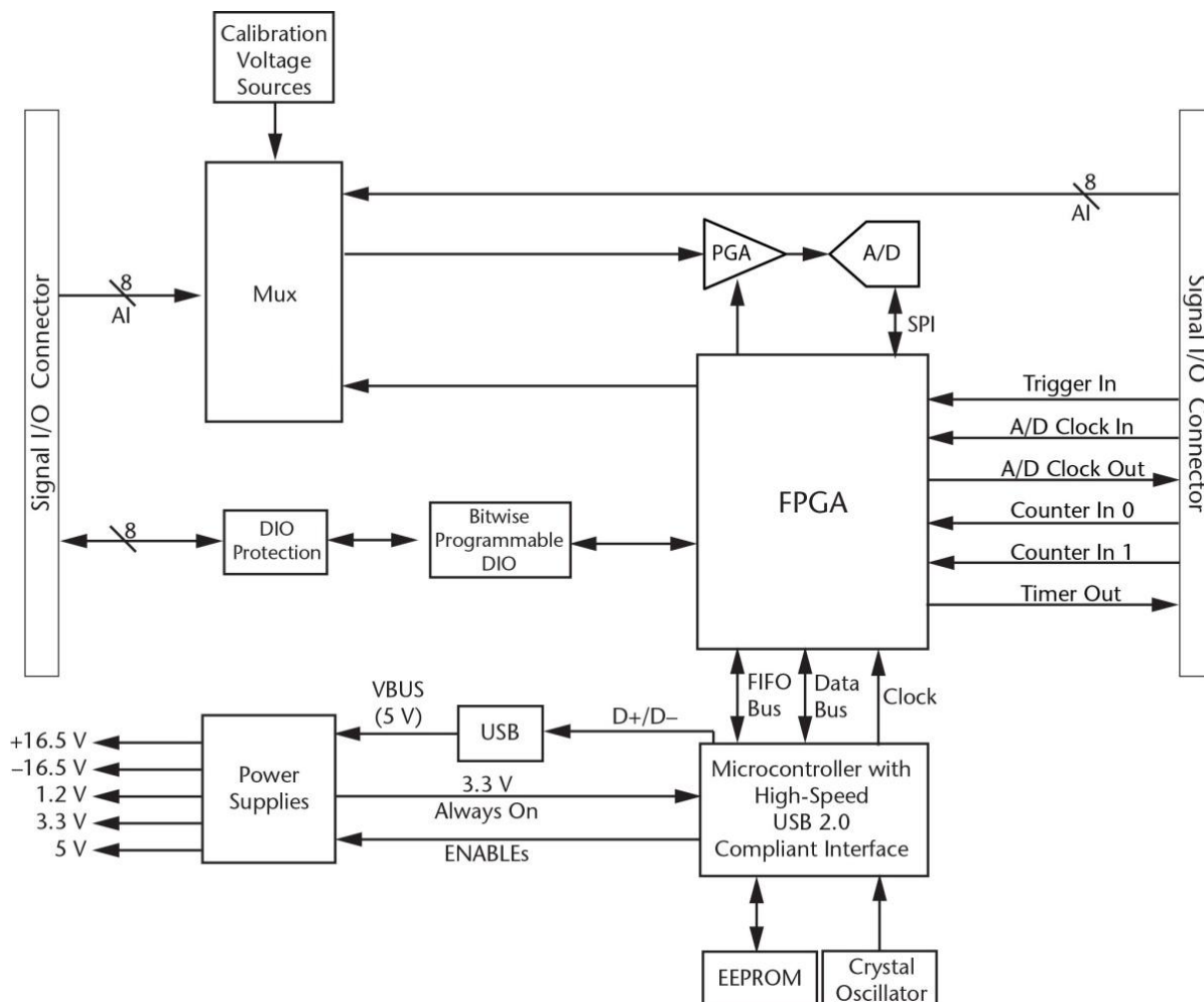

Figure 1. Functional block diagram

Installing the USB-1608GX

Unpacking

As with any electronic device, you should take care while handling to avoid damage from static electricity. Before removing the device from its packaging, ground yourself using a wrist strap or by simply touching the computer chassis or other grounded object to eliminate any stored static charge.

Contact us immediately if any components are missing or damaged.

Installing the software

Refer to the MCC DAQ Quick Start for instructions on installing the software on the MCC DAQ CD. Refer to the device product page on the Measurement Computing website for information about the included and optional software supported by the USB-1608GX.

Install the software before you install your device

The driver needed to run the USB-1608GX is installed with the software. Therefore, you need to install the software package you plan to use before you install the hardware.

Installing the hardware

To connect a USB-1608GX to your system, turn on your computer and connect the USB cable to an available USB port on the computer or to an external USB hub connected to the computer. Connect the other end of the USB cable to the USB connector on the device. No external power is required.

When you connect the device for the first time, a **Found New Hardware** dialog opens when the operating system detects the device. The dialog closes after the device is installed.

A green **Status** LED indicates the device status. When the LED is on, the device is powered and ready for operation. When the LED is off, the device is not powered or did not initialize. Figure 3 on page 9 shows the location of the **Status** LED. If the **Status** LED is on but then turns off, the computer has lost communication with the device. To restore communication, disconnect the USB cable from the computer and then reconnect it. This should restore communication, and the LED should turn on.

Caution! Do not disconnect any device from the USB bus while the computer is communicating with the USB-1608GX, or you may lose data and/or your ability to communicate with the device.

Calibrating

Self-calibration

The USB-1608GX supports self-calibration with InstaCal. Calibrate the device whenever the ambient temperature changes by more than ± 10 °C from the last self-calibration.

Factory calibration

The Measurement Computing Manufacturing Test department performs the initial factory calibration. Contact Measurement Computing for details about how to return your device and have it calibrated to the factory specifications.

Firmware updates

Your DAQ device contains firmware that can be updated in the field if required. Firmware is available for download at www.mccdaq.com/firmware.aspx. We recommend that you check this page periodically to see if an update to your device firmware is available.

Functional Details

Analog input modes

The USB-1608GX device can acquire analog input data in two basic modes – software paced and hardware paced.

Software paced

You can acquire one analog sample at a time in software paced mode. You initiate the A/D conversion with a software command. The analog value is converted to digital data and returned to the computer. Repeat this procedure until you have the total number of samples that you want.

The sample rate in software paced mode is system-dependent and can range from 33 S/s to 4000 S/s.

Hardware paced

You can acquire data from up to 16 channels in hardware paced mode. The analog data is continuously acquired, converted to digital values, and written into the FIFO buffer on the device until you stop the scan. The FIFO buffer is serviced in blocks as the data is transferred from the FIFO buffer to the computer memory buffer. You start a continuous scan with either a software command or with an external hardware trigger event.

The maximum sampling rate in hardware paced mode from one to 16 channels is 500 kS/s aggregate.

Burst mode

When using the onboard pacer, you can enable burst mode for more precise timing between samples. When burst mode is enabled, each successive channel in a scan is sampled at the maximum A/D rate. This ensures that samples from each channel are taken as close as possible to the same absolute point in time. When burst mode is disabled, data is sampled at evenly spaced intervals, allowing maximum settling time and best amplitude accuracy. Multi-channel scanning with burst mode enabled and disabled is shown in Figure 2.

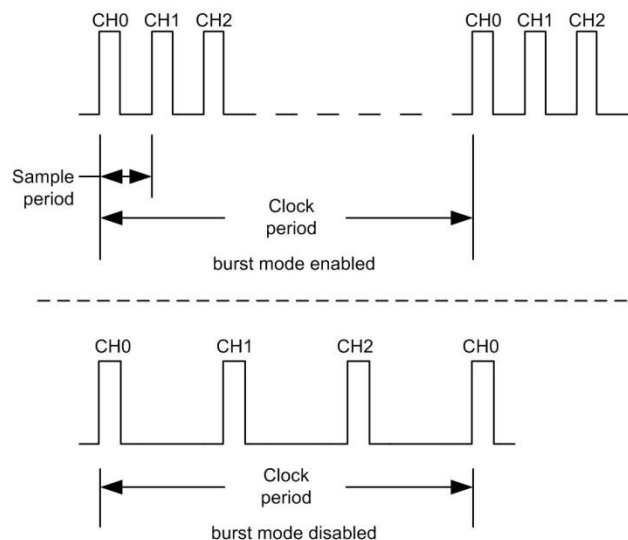

Figure 2. Multi-channel scan with burst mode enabled and disabled

The burst mode sample period is 2 μ s.

You can trigger the acquisition with the external trigger, and control the clock period with the internal or external A/D pacer clock. Pacing from the external clock always operates with burst mode enabled.

External components

The USB-1608GX has the following external components (see Figure 3):

- USB connector
- LEDs
- Screw terminals

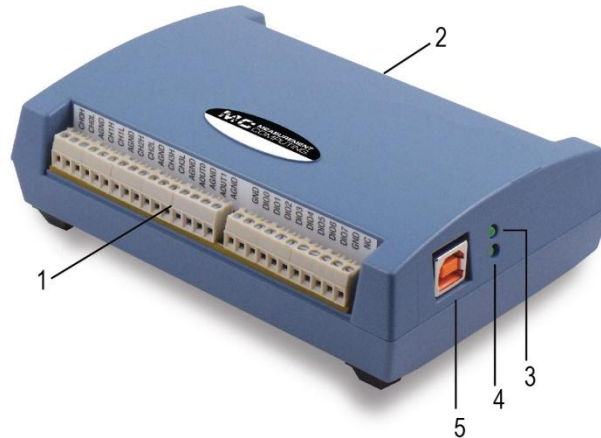

- | | | | |
|---|------------------------------|---|---------------|
| 1 | Screw terminal pins 1 to 27 | 4 | Activity LED |
| 2 | Screw terminal pins 28 to 54 | 5 | USB connector |
| 3 | Status LED | | |

Figure 3. External components

USB connector

The USB connector provides +5 V power and communication. No external power supply is required.

LEDs

The USB-1608GX has two LEDs – **Status** and **Activity**.

- The **Status** LED turns on when the device is detected and installed on the computer.
- The **Activity** LED blinks when data is transferred, and is off otherwise.

Figure 3 shows the location of each LED.

Screw terminals

The screw terminals provide the following connections:

- 16 SE (**CH0** to **CH15**) or eight DIFF (**CH0H/CH0L** to **CH7H/CH7L**) analog inputs
- Eight digital I/O bits (**DIO0** to **DIO7**)
- One external clock input (**AICKI**) and one external clock output (**AICKO**) for analog inputs
- One digital trigger input (**TRIG**)
- Two counter inputs (**CTR0**, **CTR1**)
- One timer output (**TMR**)
- One power output (**+5V**)
- Analog ground (**AGND**) and digital ground (**GND**) connections

The single-ended mode pinout is shown in Figure 4, and the differential mode pinout is shown in Figure 5.

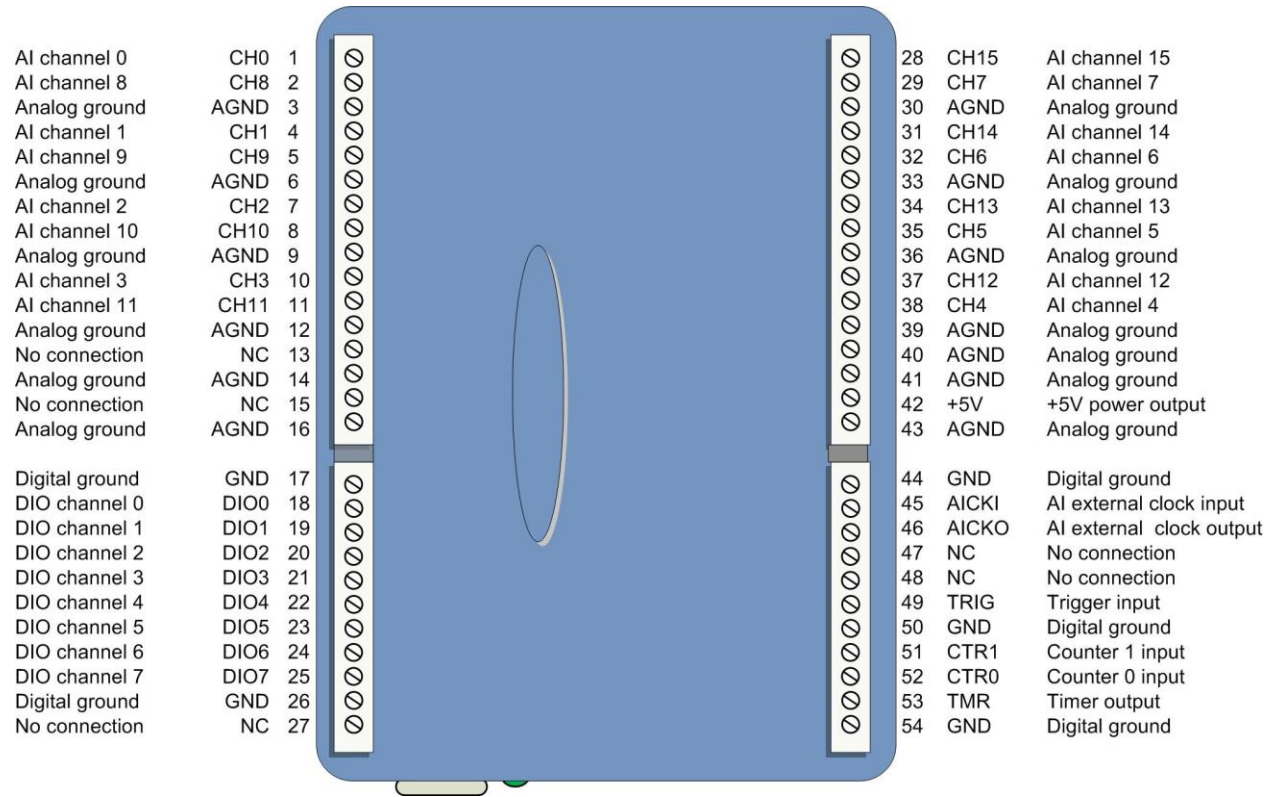

Figure 4. SE mode pinout

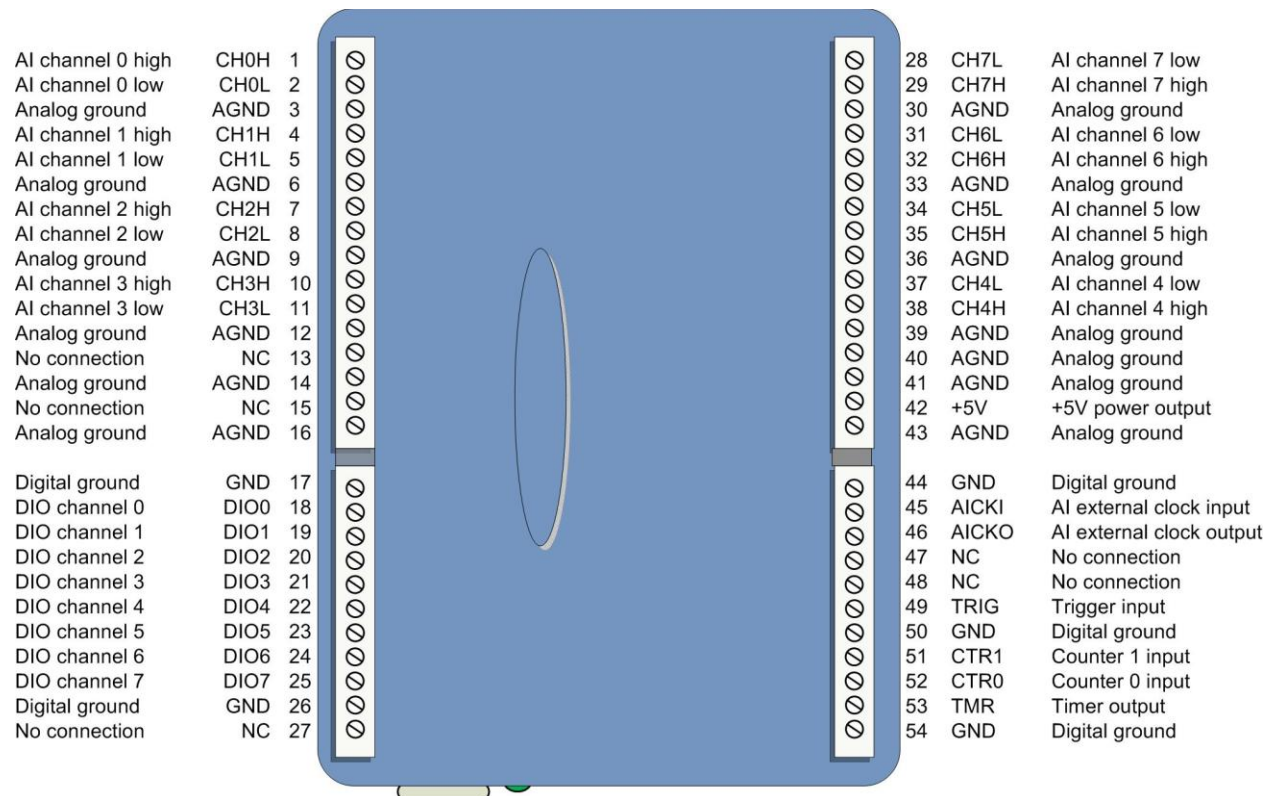

Figure 5. DIFF mode pinout

Signal connections

Analog input

You can configure the analog inputs for SE or DIFF mode. The input voltage range is software selectable for ± 10 V, ± 5 V, ± 2 V, or ± 1 V.

With SE mode, connect up to 16 inputs to screw terminals **CH0** to **CH15**. SE mode requires two wires:

- Connect one wire to the signal you want to measure (**CH x**).
- Connect one wire to the analog ground reference (**AGND**).

Refer to Figure 4 on page 10 for the location of the SE inputs.

With DIFF mode, connect up to eight differential inputs to screw terminals **CH0H/CH0L** to **CH7H/CH7L**. DIFF mode requires two wires plus a ground reference:

- Connect one wire to the high/positive signal (**CH x H**).
- Connect one wire to the low/negative signal (**CH x L**).
- Connect one wire to the analog ground reference (**AGND**).

Refer to Figure 5 on page 10 for the location of the DIFF inputs.

Floating voltage source

When connecting DIFF voltage inputs to a "floating" voltage source, make sure the DIFF input channel has a DC return path to ground. To create this path, connect a resistor from each low channel input to an AGND pin. A value of approximately 100 k Ω can be used for most applications.

Leave unused input channels either floating or tied to an AGND terminal. Source impedances should be kept as small as possible to avoid settling time and accuracy errors.

Figure 6 shows DIFF channels 0-3 connected to a ground path resistor.

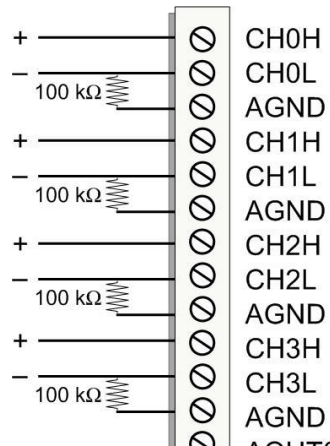

Figure 6. DIFF connections with ground path resistor

Channel-gain queue

The USB-1608GX channel-gain queue feature allows you to configure a list of channels, modes, and gains for each scan. The settings are stored in a channel-gain queue list that is written to local memory on the device.

The channel-gain queue list contains one or more channel numbers, modes, and range settings. You can configure up to 16 elements. The channels can be listed in any order, and can include duplicate channels for sampling at different ranges.

An example of a 4-element list is shown in the table below.

Sample channel-gain queue list

Element	Channel	Range	Mode
0	CH5	BIP5V	SE
1	CH1	BIP10V	DIFF
2	CH15	BIP1V	SE
3	CH5	BIP5V	SE

Carefully match the gain to the expected voltage range on the associated channel or an over range condition may occur. Although this condition does not damage the device, it does produce a useless full-scale reading, and can introduce a long recovery time due to saturation of the input channel.

For more information about analog signal connections

For more information about analog input connections, refer to the *Guide to DAQ Signal Connections* (available on our web site at www.mccdaq.com/signals/signals.pdf).

External clock I/O

The device has one external clock input (**AICKI**) and one external clock output (**AICKO**) for the analog inputs.

- When using an external clock, **AICKO** outputs the pulse generated from **AICKI**.
- When using the internal clock, **AICKO** outputs the ADC scan clock.

Digital I/O

You can connect up to eight digital I/O lines to **DIO0** through **DIO7**. Each digital channel is individually configurable for input or output. The digital I/O terminals can detect the state of any TTL-level input. Refer to the schematic shown in Figure 7.

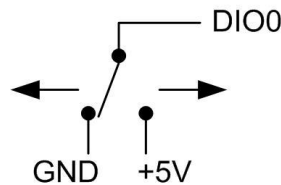

Figure 7. Schematic showing switch detection by digital channel DIO0

If you set the switch to the +5 V input, DIO0 reads *TRUE* (1). If you move the switch to GND, DIO0 reads *FALSE* (0).

Internal pull-up/down configuration

Unconnected inputs are pulled low by default to 0 V through 47 k Ω resistors via jumper **W1** on the circuit board. The pull-up/pull-down voltage is common to all 47 k Ω resistors. Complete the following steps to configure these inputs to pull high (+5V).

Caution! The discharge of static electricity can damage some electronic components. Before removing the device from its housing, ground yourself using a wrist strap or touch the computer chassis or other grounded object to eliminate any stored static charge.

1. Turn the device over and rest the top of the housing on a flat, stable surface.
2. Peel off the four rubber feet on the bottom of the device to access the screws.
3. Remove the four screws from the bottom of the device.
4. Hold both the top and bottom sections together, turn the device over and rest it on the surface, then carefully remove the top section of the case to expose the circuit board.

- Configure jumper **W1** for either pull-up or pull-down. The jumper is configured by default for pull-down. Figure 8 shows the location of the jumper on the board.

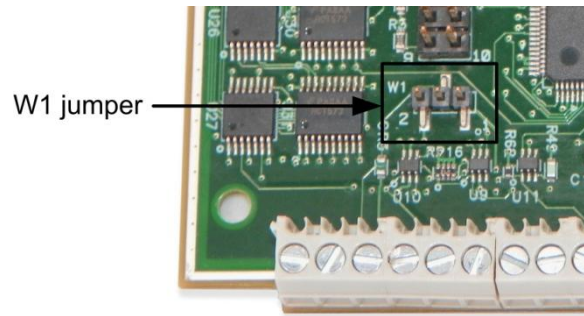

Figure 8. W1 jumper location

Figure 9 shows the jumper configured for pull-up and pull-down.

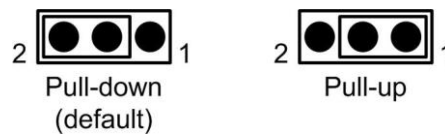

Figure 9. W1 jumper configurations

- Replace the top section of the case, and fasten it to the bottom section with the four screws. Replace the rubber feet onto each screw.

For more information about digital signal connections

For general information about digital signal connections and digital I/O techniques, refer to the *Guide to Signal Connections* (available on our web site at www.mccdaq.com/signals/signals.pdf).

Trigger input

The **TRIG** terminal is an external digital trigger input. The trigger mode is software selectable for edge or level sensitive.

- Edge sensitive mode is configurable for rising or falling edge.
- Level sensitive mode is configurable for high or low level.

The default setting at power up is edge sensitive, rising edge.

Retrigger mode

Retrigger mode lets you set up repetitive analog input or output trigger events. The trigger is automatically re-armed after it is activated. Use software to set the A/D or D/A trigger count (the number of samples you want per trigger).

Counter input

The **CTR0** and **CTR1** terminals are 32-bit event counters that can accept frequency inputs up to 20 MHz. The internal counter increments when the TTL levels transition from low to high.

Timer output

The **TMR** terminal is a pulse width modulation (PWM) timer output that can generate a pulse output with a programmable frequency in the range of 0.0149 Hz to 32 MHz. The timer output parameters are software selectable. Figure 10 shows the timer output schematic.

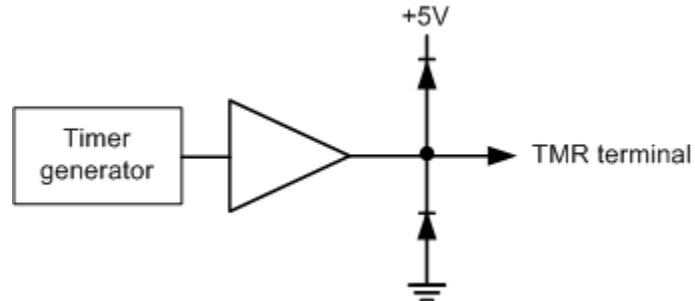

Figure 10. Timer output schematic

Power output

The **+5V** terminal can output up to 10 mA maximum. You can use this terminal to supply power to external devices or circuitry.

Caution! The **+5V** terminal is an output. Do not connect to an external power supply or you may damage the device and possibly the computer.

Ground

The analog ground (**AGND**) terminals provide a common ground for all analog channels.

The digital ground (**GND**) terminals provide a common ground for the digital, counter, timer, and clock channels and the power terminal.

Mechanical drawings

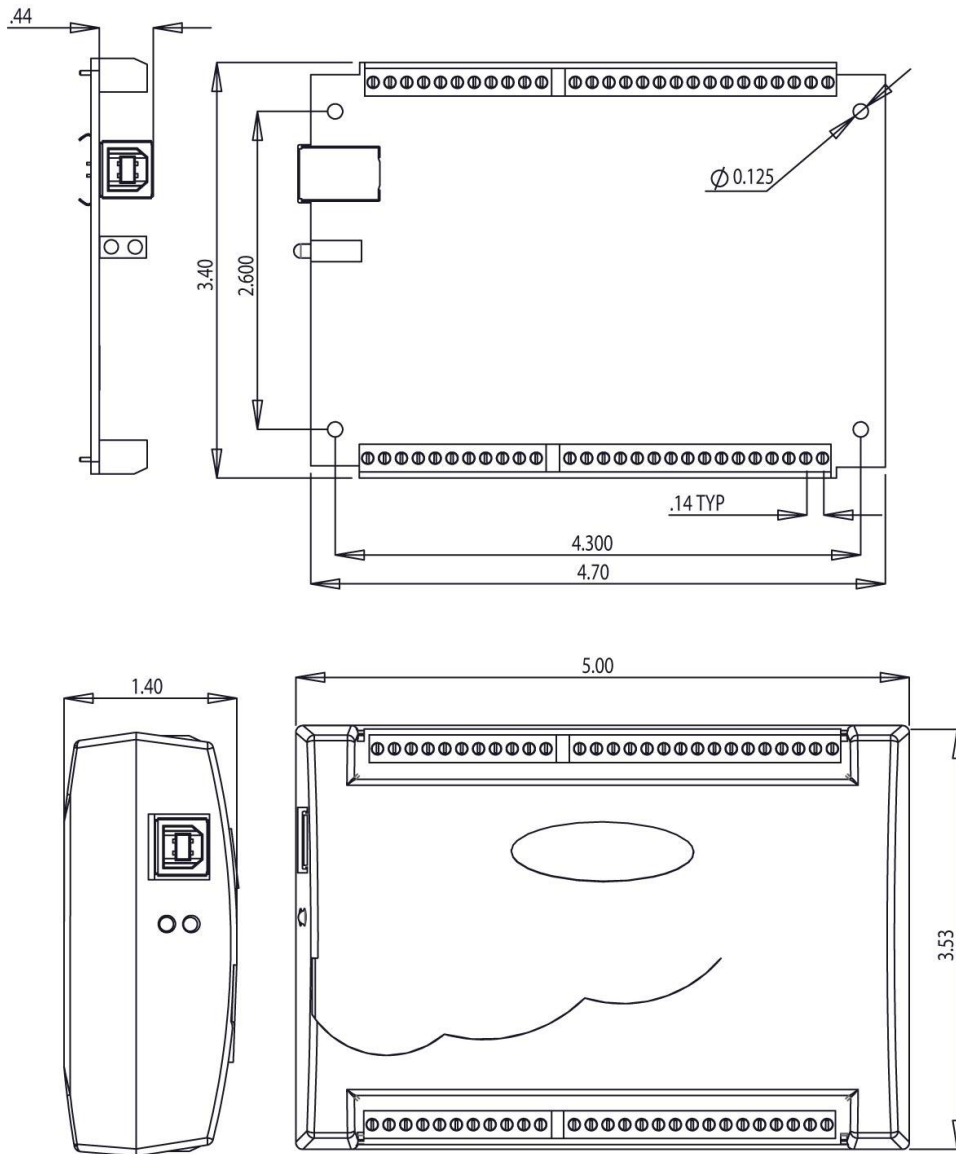

Figure 11. USB-1608GX circuit board (top) and enclosure dimensions

Specifications

All specifications are subject to change without notice.

Typical for 25 °C unless otherwise specified.

Specifications in *italic text* are guaranteed by design.

Analog input

Table 1. General analog input specifications

Parameter	Condition	Specification
A/D converter type		Successive approximation
ADC resolution		16 bits
Number of channels		8 differential, 16 single-ended Software-selectable
Input voltage range		± 10 V, ± 5 V, ± 2 V, ± 1 V Software-selectable per channel
<i>Absolute max input voltage</i>	<i>CHx relative to AGND</i>	<ul style="list-style-type: none"> ■ ± 25 V max (power on) ■ ± 15 V max (power off)
<i>Input impedance</i>		<ul style="list-style-type: none"> ■ $1\text{ G}\Omega$ (power on) ■ $820\ \Omega$ (power off)
<i>Input bias current</i>		± 10 nA
Input bandwidth	All input ranges, small signal (-3 dB)	870 kHz
<i>Input capacitance</i>		60 pf
Max working voltage (signal + common mode)	± 10 V range	± 10.2 V max relative to AGND
	± 5 V range	± 10.2 V max relative to AGND
	± 2 V range	± 9.5 V max relative to AGND
	± 1 V range	± 9.0 V max relative to AGND
Common mode rejection ratio	($f_{IN} = 60$ Hz, all input ranges)	86 dB
Crosstalk	Adjacent differential mode channels, DC to 100 kHz	-75 dB
Input coupling		DC
Sampling rate		0.0149 Hz to 500 kHz; software-selectable
Trigger source		TRIG (see <i>External trigger</i> on page 18)
Sample clock source		Internal A/D clock or external A/D clock (AICKI pin)
Burst mode		2 μ s Software-selectable using the internal A/D clock; always enabled when using the external clock (AICKI pin).
Throughput	Software paced	33 to 4000 S/s typ, system dependent
	Hardware paced	500 kS/s max
Channel gain queue	Up to 16 elements	Software-selectable range for each channel
Warm-up time		15 minutes min

Accuracy

Analog input DC voltage measurement accuracy

Table 2. DC Accuracy components and specifications. All values are (\pm)

Range	Gain error (% of reading)	Offset error (μ V)	INL error (% of range)	Absolute accuracy at Full Scale (μ V)	Gain temperature coefficient (% reading/ $^{\circ}$ C)	Offset temperature coefficient (μ V/ $^{\circ}$ C)
± 10 V	0.024	915	0.0076	4075	0.0014	47
± 5 V	0.024	686	0.0076	2266	0.0014	24
± 2 V	0.024	336	0.0076	968	0.0014	10
± 1 V	0.024	245	0.0076	561	0.0014	5

Noise performance

For the peak-to-peak noise distribution test, a differential input channel is connected to AGND at the input terminal block, and 32,000 samples are acquired at the maximum rate available at each setting.

Table 3. Noise performance specifications

Range	Counts	LSBrms
± 10 V	6	0.91
± 5 V	6	0.91
± 2 V	7	1.06
± 1 V	9	1.36

Settling time

Settling time is defined as the accuracy that can be expected after one conversion when switching from a channel with a DC input at one extreme of full scale to another channel with a DC input at the other extreme of full scale. Both input channels are configured for the same input range.

Table 4. Input settling time specifications in μ S, typical

Range	2 μ S settling accuracy (% FSR)	4 μ S settling accuracy (% FSR)	9 μ S settling accuracy (% FSR)
± 10 V	0.1251	0.0031	0.0015
± 5 V	0.0687	0.0031	0.0015
± 2 V	0.0687	0.0031	0.0015
± 1 V	0.0687	0.0031	0.0015

Analog input calibration

Table 5. Analog input calibration specifications

Parameter	Specification
Recommended warm-up time	15 minutes min
Calibration method	Self-calibration (firmware)
Calibration interval	1 year (factory calibration)
Calibration reference	+5 V, ± 2.5 mV max. Actual measured values stored in EEPROM.
	Tempco: 5 ppm/ $^{\circ}$ C max
	Long term stability: 15 ppm/1000 hours

Digital input/output

Table 6. Digital I/O specifications

Parameter	Specification
Digital type	CMOS
Number of I/O	8
Configuration	Each bit may be configured as input (power on default) or output
Pull-up configuration	The port has 47 k Ω resistors configurable as pull-ups or pull-downs (default) via internal jumper (W1).
Digital I/O transfer rate (system-paced)	33 to 8000 port reads/writes or single bit reads/writes per second typ, system dependent.
Input high voltage	2.0 V min 5.5 V absolute max
Input low voltage	0.8 V max -0.5 V absolute min 0 V recommended min
Output high voltage	4.4 V min (IOH = -50 μ A) 3.76 V min (IOH = -2.5 mA)
Output low voltage	0.1 V max (IOL = 50 μ A) 0.44 V max (IOL = 2.5 mA)
Output current	\pm 2.5 mA max

External trigger

Table 7. External trigger specifications

Parameter	Specification
Trigger source	TRIG input
Trigger mode	Software programmable for edge or level sensitive, rising or falling edge, high or low level. Power on default is edge sensitive, rising edge.
Trigger latency	1 μ s + 1 clock cycle max
Trigger pulse width	100 ns min
Input type	Schmitt trigger, 33 Ω series resistor and 49.9 k Ω pull-down to ground
Schmitt trigger hysteresis	0.4 V to 1.2 V
Input high voltage	2.2 V min 5.5 V absolute max
Input low voltage	1.5 V max -0.5 V absolute min 0 V recommended min

External clock input/output

Table 8. External clock I/O specifications

Parameter	Specification
Terminal names	AICKI, AICKO
Terminal types	AICKI: Input, active on rising edge AICKO: Output, power on default is 0 V, active on rising edge
Terminal descriptions	AICKI: Receives sampling clock from external source AICKO: Outputs the internal A/D sampling clock, or the pulse generated from AICKI when in external clock mode.
Input clock rate	500 kHz max
Clock pulse width	AICKI: 400 ns min AICKO: 400 ns min
Input type	Schmitt trigger, 33 Ω series resistor, 47 k Ω pull-down to ground
Schmitt trigger hysteresis	0.4 V to 1.2 V
Input high voltage	2.2 V min 5.5 V absolute max
Input low voltage	1.5 V max -0.5 V absolute min 0 V recommended min
Output high voltage	4.4 V min (IOH = -50 μ A) 3.76 V min (IOH = -2.5 mA)
Output low voltage	0.1 V max (IOL = 50 μ A) 0.44 V max (IOL = 2.5 mA)
Output current	\pm 2.5 mA max

Counter

Table 9. Counter specifications

Parameter	Specification
Terminal names	CTR0, CTR1
Number of channels	2 channels
Resolution	32-bit
Counter type	Event counter
Input type	Schmitt trigger, 33 Ω series resistor, 47 k Ω pull-down to ground
Input source	CTR0 (pin 52) CTR1 (pin 51)
Counter read/writes rates (software paced)	33 to 8000 reads/writes per second typ, system dependent
Input high voltage	2.2 V min, 5.5 V max
Input low voltage	1.5 V max, -0.5 V min
Schmitt trigger hysteresis	0.4 V min, 1.2 V max
Input frequency	20 MHz, max
High pulse width	25 ns, min
Low pulse width	25 ns, min

Timer

Table 10. Timer specifications

Parameter	Specification
Terminal name	TMR
Timer type	PWM output with count, period, delay, and pulse width registers
Output value	Default state is idle low with pulses high, software-selectable output invert
Internal clock frequency	64 MHz
Register widths	32-bit
High pulse width	15.625 ns min
Low pulse width	15.625 ns min
Output high voltage	4.4 V min (IOH = -50 μ A) 3.76 V min (IOH = -2.5 mA)
Output low voltage	0.1 V max (IOL = 50 μ A) 0.44 V max (IOL = 2.5 mA)
Output current	\pm 2.5 mA max

Memory

Table 11. Memory specifications

Parameter	Specification
Data FIFO	4 kS analog input
Non-volatile memory	32 KB (28 KB firmware storage, 4 KB calibration/user data)

Power

Table 12. Power specifications

Parameter	Condition	Specification
Supply current (Note 1)	Quiescent current	230 mA
+5 V user output voltage range	Available at terminal block pin 42	4.5 V min to 5.25 V max
+5 V user output current	Available at terminal block pin 42	10 mA max

Note 1: This is the total quiescent current requirement for the device that includes up to 10 mA for the Status LED. This does not include any potential loading of the digital I/O bits or the +5V terminal.

USB

Table 13. USB specifications

Parameter	Specification
USB device type	USB 2.0 (high-speed)
Device compatibility	USB 1.1, USB 2.0
USB cable type	A-B cable, UL type AWM 2725 or equivalent. (Min 24 AWG VBUS/GND, min 28 AWG D+/D-)
USB cable length	3 m (9.84 ft) max

Environmental

Table 14. Environmental specifications

Parameter	Specification
Operating temperature range	0 °C to 55 °C max
Storage temperature range	-40 °C to 85 °C max
Humidity	0% to 90% non-condensing max

Mechanical

Table 15. Mechanical specifications

Parameter	Specification
Dimensions (L × W × H)	127 × 89.9 × 35.6 mm (5.00 × 3.53 × 1.40 in.)
User connection length	3 m (9.84 ft) max

Screw terminal connector

Table 16. Screw terminal connector specifications

Parameter	Specification
Connector type	Screw terminal
Wire gauge range	16 AWG to 30 AWG

Differential mode pinout

Table 17. 8-channel differential mode pinout

Pin	Signal name	Pin description	Pin	Signal name	Pin description
1	CH0H	AI channel 0 HI	28	CH7L	AI channel 7 LO
2	CH0L	AI channel 0 LO	29	CH7H	AI channel 7 HI
3	AGND	Analog ground	30	AGND	Analog ground
4	CH1H	AI channel 1 HI	31	CH6L	AI channel 6 LO
5	CH1L	AI channel 1 LO	32	CH6H	AI channel 6 HI
6	AGND	Analog ground	33	AGND	Analog ground
7	CH2H	AI channel 2 HI	34	CH5L	AI channel 5 LO
8	CH2L	AI channel 2 LO	35	CH5H	AI channel 5 HI
9	AGND	Analog ground	36	AGND	Analog ground
10	CH3H	AI channel 3 HI	37	CH4L	AI channel 4 LO
11	CH3L	AI channel 3 LO	38	CH4H	AI channel 4 HI
12	AGND	Analog ground	39	AGND	Analog ground
13	NC	No connection	40	AGND	Analog ground
14	AGND	Analog ground	41	AGND	Analog ground
15	NC	No connection	42	+5V	+5V power output
16	AGND	Analog ground	43	AGND	Analog ground
	empty			empty	
17	GND	Digital ground	44	GND	Digital ground
18	DIO0	DIO channel 0	45	AICKI	AI clock input
19	DIO1	DIO channel 1	46	AICKO	AI clock output
20	DIO2	DIO channel 2	47	NC	No connection
21	DIO3	DIO channel 3	48	NC	No connection
22	DIO4	DIO channel 4	49	TRIG	Trigger input
23	DIO5	DIO channel 5	50	GND	Digital ground
24	DIO6	DIO channel 6	51	CTR1	Counter 1 input
25	DIO7	DIO channel 7	52	CTR0	Counter 0 input
26	GND	Digital ground	53	TMR	Timer output
27	NC	No connection	54	GND	Digital ground

Single-ended mode pinout

Table 18. 16-channel single-ended mode pinout

Pin	Signal name	Pin description	Pin	Signal name	Pin description
1	CH0	AI channel 0	28	CH15	AI channel 15
2	CH8	AI channel 8	29	CH7	AI channel 7
3	AGND	Analog ground	30	AGND	Analog ground
4	CH1	AI channel 1	31	CH14	AI channel 14
5	CH9	AI channel 9	32	CH6	AI channel 6
6	AGND	Analog ground	33	AGND	Analog ground
7	CH2	AI channel 2	34	CH13	AI channel 13
8	CH10	AI channel 10	35	CH5	AI channel 5
9	AGND	Analog ground	36	AGND	Analog ground
10	CH3	AI channel 3	37	CH12	AI channel 12
11	CH11	AI channel 11	38	CH4	AI channel 4
12	AGND	Analog ground	39	AGND	Analog ground
13	NC	No connection	40	AGND	Analog ground
14	AGND	Analog ground	41	AGND	Analog ground
15	NC	No connection	42	+5V	+5V power output
16	AGND	Analog ground	43	AGND	Analog ground
	empty			empty	
17	GND	Digital ground	44	GND	Digital ground
18	DIO0	DIO channel 0	45	AICKI	AI clock input
19	DIO1	DIO channel 1	46	AICKO	AI clock output
20	DIO2	DIO channel 2	47	NC	No connection
21	DIO3	DIO channel 3	48	NC	No connection
22	DIO4	DIO channel 4	49	TRIG	Trigger input
23	DIO5	DIO channel 5	50	GND	Digital ground
24	DIO6	DIO channel 6	51	CTR1	Counter 1 input
25	DIO7	DIO channel 7	52	CTR0	Counter 0 input
26	GND	Digital ground	53	TMR	Timer output
27	NC	No connection	54	GND	Digital ground

CE Declaration of Conformity

Manufacturer: Measurement Computing Corporation
Address: 10 Commerce Way
Suite 1008
Norton, MA 02766
USA

Category: Electrical equipment for measurement, control and laboratory use.

Measurement Computing Corporation declares under sole responsibility that the products

USB-1608GX

to which this declaration relates is in conformity with the relevant provisions of the following standards or other documents:

EC EMC Directive 2004/108/EC: General Requirements, EN 61326-1:2006 (IEC 61326-1:2005).

Emissions:

- EN 55011 (2007) / CISPR 11(2003): Radiated emissions: Group 1, Class A
- EN 55011 (2007) / CISPR 11(2003): Conducted emissions: Group 1, Class A

Immunity: EN 61326-1:2006, Table 3.

- IEC 61000-4-2 (2001): Electrostatic Discharge immunity.
- IEC 61000-4-3 (2002): Radiated Electromagnetic Field immunity.

To maintain compliance to the standards of this declaration, the following conditions must be met.

- The host computer, peripheral equipment, power sources, and expansion hardware must be CE compliant.
- All I/O cables must be shielded, with the shields connected to ground.
- I/O cables must be less than 3 meters (9.75 feet) in length.
- The host computer must be properly grounded.
- The host computer must be USB 2.0 compliant.
- Equipment must be operated in a controlled electromagnetic environment as defined by Standards EN 61326-1:2006, or IEC 61326-1:2005.

Note: Data acquisition equipment may exhibit noise or increased offsets when exposed to high RF fields (>1V/m) or transients.

Declaration of Conformity based on tests conducted by Chomerics Test Services, Woburn, MA 01801, USA in October, 2010. Test records are outlined in Chomerics Test Report #EMI5736.10.

We hereby declare that the equipment specified conforms to the above Directives and Standards.



Carl Haapaoja, Director of Quality Assurance

Measurement Computing Corporation
10 Commerce Way
Suite 1008
Norton, Massachusetts 02766
(508) 946-5100
Fax: (508) 946-9500
E-mail: info@mccdaq.com
www.mccdaq.com