

AI-EXP32

Analog Input Expansion Device for USB-2416 Series Devices

User's Guide

Your new Measurement Computing product comes with a fantastic extra —

Management committed to your satisfaction!

Thank you for choosing a Measurement Computing product—and congratulations! You own the finest, and you can now enjoy the protection of the most comprehensive warranties and unmatched phone tech support. It's the embodiment of our mission:

To provide data acquisition hardware and software that will save time and save money.

Simple installations minimize the time between setting up your system and actually making measurements. We offer quick and simple access to outstanding live FREE technical support to help integrate MCC products into a DAQ system.

Limited Lifetime Warranty: Most MCC products are covered by a limited lifetime warranty against defects in materials or workmanship for the life of the product, to the original purchaser, unless otherwise noted. Any products found to be defective in material or workmanship will be repaired, replaced with same or similar device, or refunded at MCC's discretion. For specific information, please refer to the terms and conditions of sale.

Harsh Environment Program: Any Measurement Computing product that is damaged due to misuse, or any reason, may be eligible for replacement with the same or similar device for 50% of the current list price. I/O boards face some harsh environments, some harsher than the boards are designed to withstand. Contact MCC to determine your product's eligibility for this program.

30 Day Money-Back Guarantee: Any Measurement Computing Corporation product may be returned within 30 days of purchase for a full refund of the price paid for the product being returned. If you are not satisfied, or chose the wrong product by mistake, you do not have to keep it.

These warranties are in lieu of all other warranties, expressed or implied, including any implied warranty of merchantability or fitness for a particular application. The remedies provided herein are the buyer's sole and exclusive remedies. Neither Measurement Computing Corporation, nor its employees shall be liable for any direct or indirect, special, incidental or consequential damage arising from the use of its products, even if Measurement Computing Corporation has been notified in advance of the possibility of such damages.

Trademark and Copyright Information

Measurement Computing Corporation, InstaCal, Universal Library, and the Measurement Computing logo are either trademarks or registered trademarks of Measurement Computing Corporation. Refer to the Copyrights & Trademarks section on mccdaq.com/legal for more information about Measurement Computing trademarks. Other product and company names mentioned herein are trademarks or trade names of their respective companies.

© 2013 Measurement Computing Corporation. All rights reserved. No part of this publication may be reproduced, stored in a retrieval system, or transmitted, in any form by any means, electronic, mechanical, by photocopying, recording, or otherwise without the prior written permission of Measurement Computing Corporation.

Notice

Measurement Computing Corporation does not authorize any Measurement Computing Corporation product for use in life support systems and/or devices without prior written consent from Measurement Computing Corporation. Life support devices/systems are devices or systems that, a) are intended for surgical implantation into the body, or b) support or sustain life and whose failure to perform can be reasonably expected to result in injury. Measurement Computing Corporation products are not designed with the components required, and are not subject to the testing required to ensure a level of reliability suitable for the treatment and diagnosis of people.

Table of Contents

Preface	
About this User's Guide	4
What you will learn from this user's guide	4
Conventions in this user's guide	4
Where to find more information	4
Chapter 1	
Introducing the AI-EXP32	5
Overview: AI-EXP32 features	5
Chapter 2	
Installing the AI-EXP32	6
What comes with your AI-EXP32 shipment?.....	6
Hardware	6
Software.....	6
Documentation.....	6
Optional components	6
Unpacking the AI-EXP32.....	6
Connecting to a USB-2416 Series device with the DSUB37 expansion connector.....	7
Connecting the device for I/O operations	7
User connectors.....	7
Screw terminal pin outs	8
Expansion connector.....	10
Associating CJC channels with thermocouple channels.....	10
Mechanical drawings	11
Chapter 3	
Specifications	12
Compatibility	12
Analog input	12
Channel configurations	13
Compatible sensors	13
Accuracy	13
Thermocouple measurement accuracy	13
Analog input DC voltage measurement accuracy:	13
Digital input/output.....	14
Power.....	15
Environmental	15
Mechanical	15
Screw terminal connector type and pin-out	15
Expansion port.....	15
Declaration of Conformity	19

About this User's Guide

What you will learn from this user's guide

This user's guide describes the Measurement Computing AI-EXP32 data acquisition device and lists device specifications.

Conventions in this user's guide

For more information

Text presented in a box signifies additional information and helpful hints related to the subject matter you are reading.

Caution! Shaded caution statements present information to help you avoid injuring yourself and others, damaging your hardware, or losing your data.

bold text **Bold** text is used for the names of objects on a screen, such as buttons, text boxes, and check boxes.

italic text *Italic* text is used for the names of manuals and help topic titles, and to emphasize a word or phrase.

Where to find more information

Additional information about the AI-EXP32 is available on our website at www.mccdaq.com. You can also contact Measurement Computing Corporation by phone, fax, or email with specific questions.

- Knowledgebase: kb.mccdaq.com
- Phone: 508-946-5100 and follow the instructions for reaching Tech Support
- Fax: 508-946-9500 to the attention of Tech Support
- Email: techsupport@mccdaq.com

Introducing the AI-EXP32

Overview: AI-EXP32 features

The AI-EXP32 is an expansion device you can use to add up to 32 single-ended analog inputs or 16 differential analog/thermocouple inputs to compatible hardware, such as USB-2416 Series devices. Each input channel is software configurable for either voltage or thermocouple. The analog inputs are provided on four rows of removable screw terminals.

The voltage measurement speed is the same as the connected USB-2416 Series device. When measuring thermocouples, configure the USB-2416 Series device for differential inputs.

The AI-EXP32 also provides up to 16 additional digital I/O channels. You can independently-configure each channel for either input or output.

Connect the AI-EXP32 to a USB-2416 Series device with the 37-pin expansion connector. The AI-EXP32 supports all of the analog/thermocouple input and digital I/O features of the USB-2416 Series device.

The AI-EXP32 is powered by the USB-2416 Series device.

Installing the AI-EXP32

What comes with your AI-EXP32 shipment?

The following items are shipped with the AI-EXP32.

Hardware

- AI-EXP32
- Expansion connector plate with four screws



Software

- MCC DAQ CD

Documentation

In addition to this hardware user's guide, you should also receive the *Quick Start Guide*. This booklet provides an overview of the MCC DAQ software you received with the device, and includes information about installing the software. Please read this booklet completely before installing any software or hardware.

Optional components

ACC-202 Din-rail kit

Accessory for mounting a AI-EXP32 to a standard DIN rail. Use the thread-forming screws to attach the DIN rail clip to your device.



Unpacking the AI-EXP32

As with any electronic device, you should take care while handling to avoid damage from static electricity. Before removing the AI-EXP32 from its packaging, ground yourself using a wrist strap or by simply touching the computer chassis or other grounded object to eliminate any stored static charge.

If any components are missing or damaged, notify Measurement Computing Corporation immediately by phone, fax, or e-mail:

- Knowledgebase: kb.mccdaq.com
- Phone: 508-946-5100 and follow the instructions for reaching Tech Support
- Fax: 508-946-9500 to the attention of Tech Support
- [Email: techsupport@mccdaq.com](mailto:techsupport@mccdaq.com)

Connecting to a USB-2416 Series device with the DSUB37 expansion connector

Use the 37-pin expansion connector to connect the AI-EXP32 to a USB-2416 Series device.

To connect the two devices directly to each other, follow these steps.

1. Disconnect the USB cable from the USB-2416 Series device.
2. Remove the external power cable from the USB-2416 Series device.
3. Connect the two devices together by inserting the AI-EXP32' DSUB37 connector into the DSUB37 connector on the USB-2416 Series device.



Figure 1. AI-EXP32 directly connected to a USB-2416-4AO

4. Turn the connected devices over and secure the connection by screwing the connection plate to both devices, as shown below.



Figure 2. AI-EXP32 secured to a USB-2416-4AO

5. Connect the external power supply to the power input port of the USB-2416 Series device, and then plug it into an AC outlet.

By connecting external power to the device before connecting the USB cable to the computer, the USB-2416- Series device informs the host computer upon connection of the USB cable that the device requires minimum power from the computer's USB port.

6. Connect the USB cable from the USB-2416 Series device to the host computer's USB port.

Connect to a USB 2.0 high speed hub to achieve the highest transfer rate (480 Mbps).

When connected to a USB 1.1 full-speed port, the transfer rate is limited to 12 Mbps.

Connecting the device for I/O operations

User connectors

The following table lists the device connectors and compatible hardware for the AI-EXP32.

User connectors and hardware

Connector type	<ul style="list-style-type: none"> ■ Six banks of removable screw-terminal blocks ■ 37-pin male DSUB connector (for connection to parent device)
Wire gauge range (screw terminals)	16 AWG to 30 AWG

Screw terminal pin outs

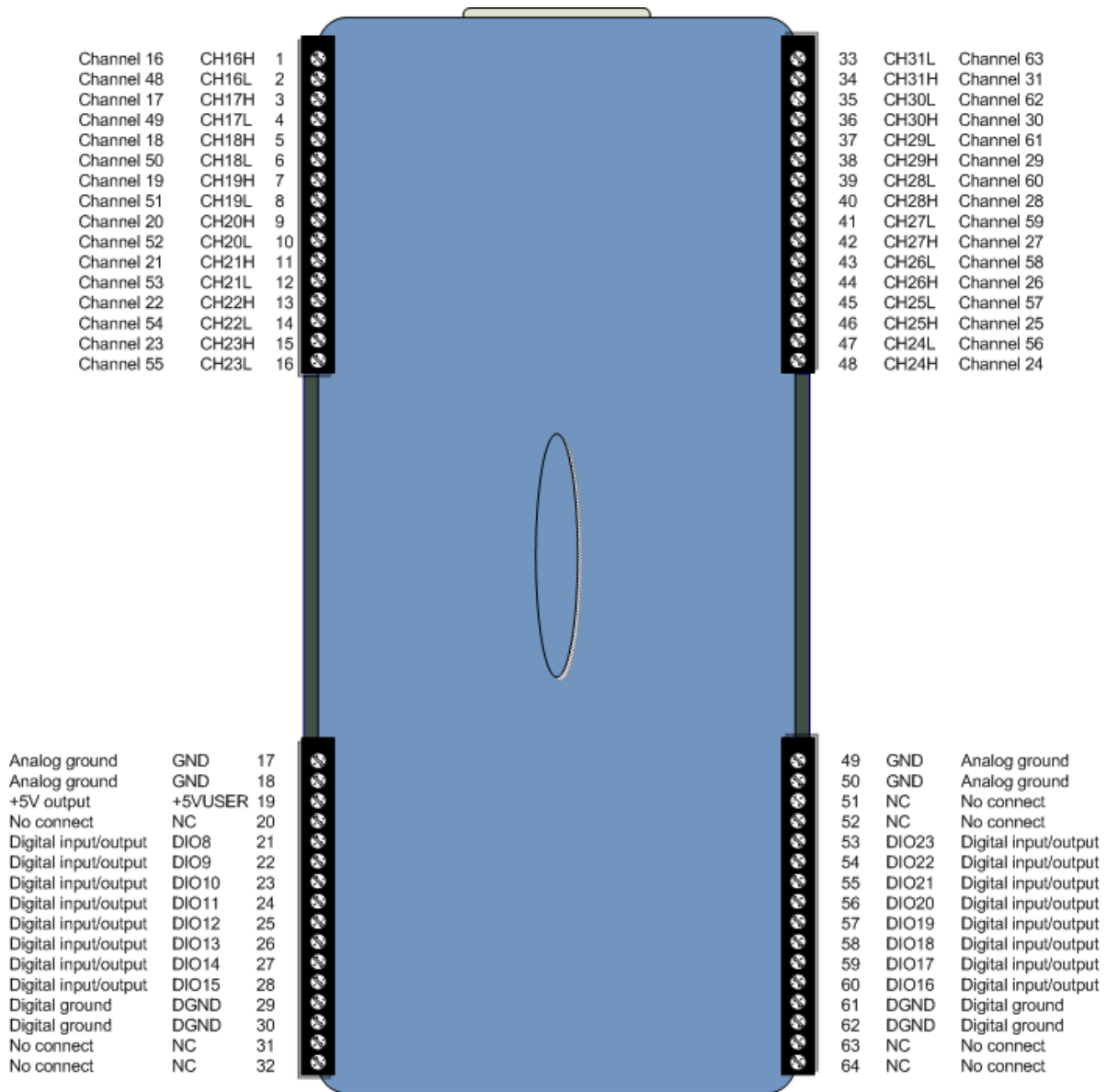

Figure 3. Single-ended mode pin out

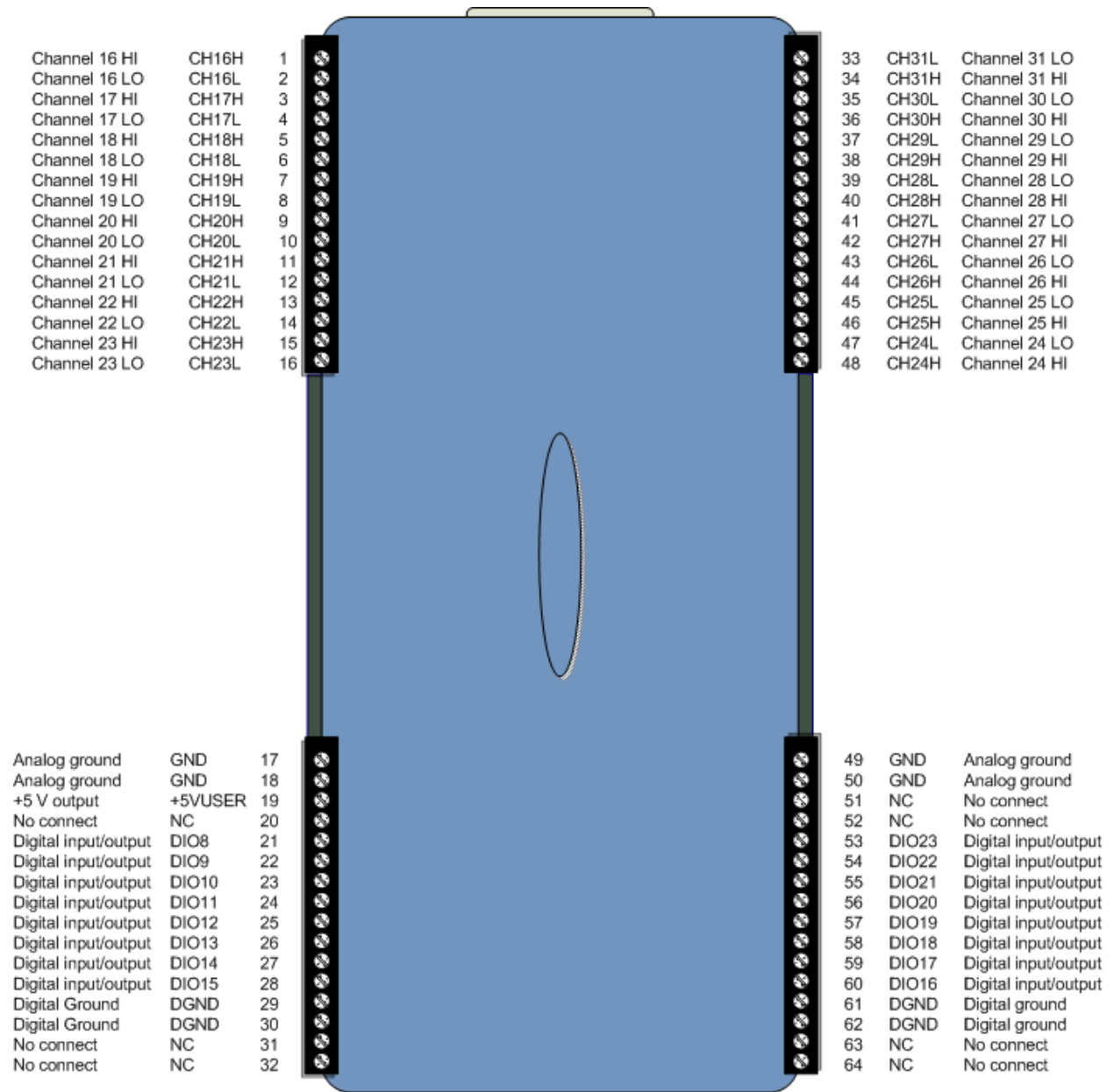

Figure 4. Differential mode pin out

Expansion connector

The AI-EXP32 has a 37-pin male DSUB connector that connects directly to the 37-pin female DSUB connector on a USB-2416 Series device.

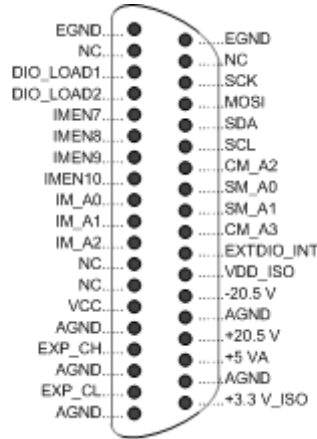

Figure 5. DSUB37 expansion connector pin out

Information on signal connections

General information regarding signal connection and configuration is available in the Guide to Signal Connections (available at www.mccdaq.com/signals/signals.pdf).

Associating CJC channels with thermocouple channels

TC channels must immediately follow their associated CJC channels in the channel array. For accurate thermocouple measurements, associate CJC channels with the TC channels as listed below.

CJC channels	TC channels
CJC6	TC8 through TC11
CJC7	TC12 through TC15
CJC8	TC16 through TC19
CJC9	TC20 through TC23
CJC10	TC24 through TC27
CJC11	TC28 through TC31

When measuring thermocouples, configure the USB-2416 Series device for differential inputs.

Mechanical drawings

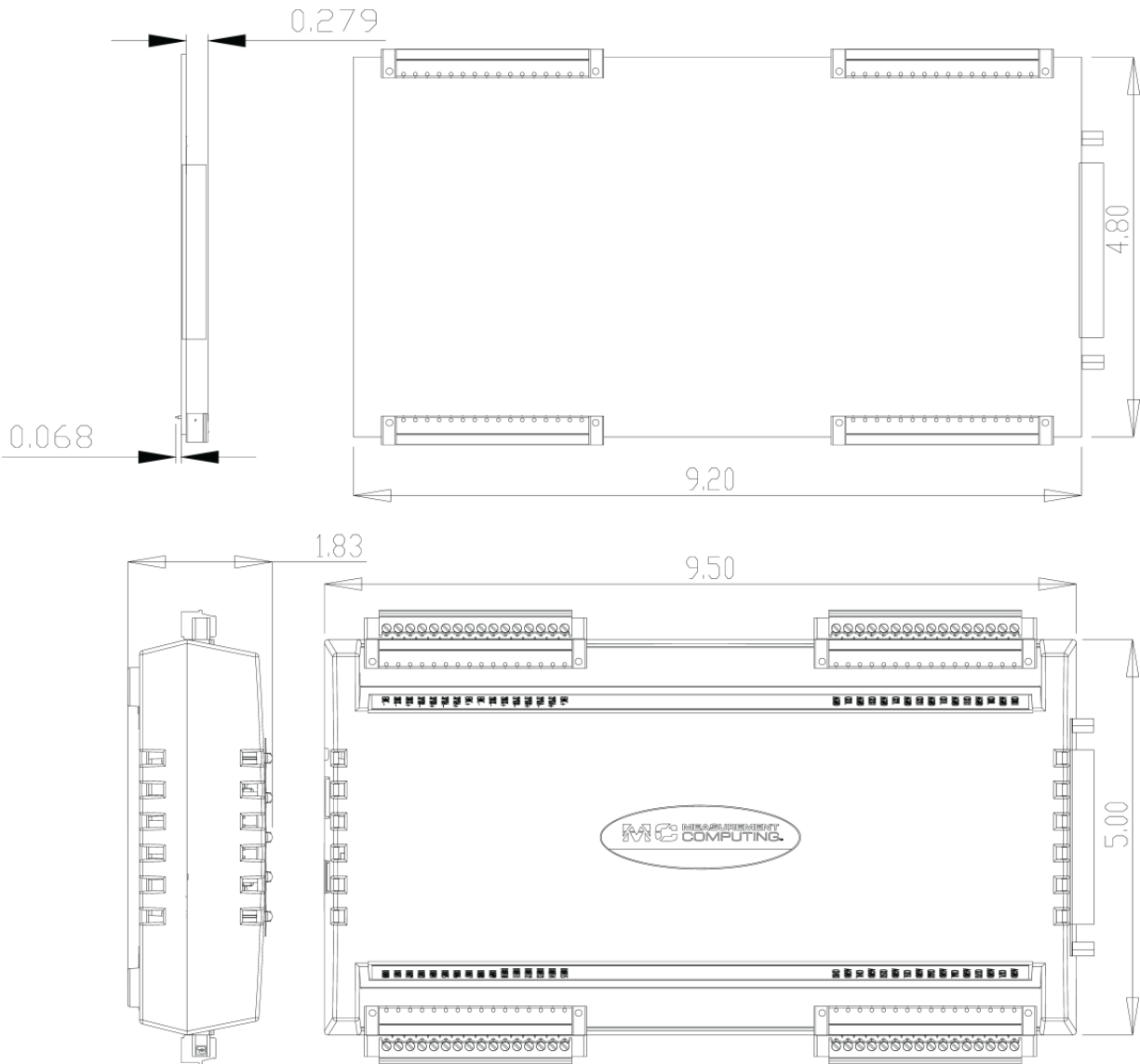

Figure 6. Circuit board (top) and enclosure dimensions

Specifications

All specifications are subject to change without notice.

Typical for 25 °C unless otherwise specified.

All specifications apply to all temperature and voltage input channels unless otherwise specified.

Specifications in *italic text* are guaranteed by design.

Compatibility

Table 1. Host product compatibility

Product name	Product description
USB-2416-4AO	<ul style="list-style-type: none"> ■ Full-speed, multiplexed 24-bit measurement system that provides up to 16 differential and up to 32 single-ended (SE) analog inputs. ■ Eight high-speed lines of digital I/O and two 32-bit counters. ■ Four 16-bit analog output channels with an update rate of 1000 S/s and an output range of ± 10 V.
USB-2416	<ul style="list-style-type: none"> ■ Full-speed, multiplexed 24-bit measurement system that provides up to 16 differential and up to 32 single-ended (SE) analog inputs. ■ Eight high-speed lines of digital I/O and two 32-bit counters.

Analog input

Table 2. General analog input specifications

Parameter	Conditions	Specification
Number of channels		Up to 32 channels individually software-configurable as single-ended or differential. Thermocouples require differential mode. For each channel configured as differential, you essentially lose a single-ended channel.
Channel configurations		Temperature sensor input, software programmable to match sensor type Voltage input
Input voltage range	Thermocouple mode	± 0.078125 V
	Voltage mode	± 20 V, ± 10 V, ± 5 V, ± 2.5 V, ± 1.25 V, ± 0.625 V, ± 0.3125 V, ± 0.15625 V, ± 0.078125 V, software- configurable
<i>Absolute maximum input voltage</i>	<i>CxH-CxL relative to GND</i>	± 30 V maximum (<i>power on</i>) ± 10 V maximum (<i>power off</i>)
<i>Input impedance</i>		2 G Ω (<i>power on</i>) 390 Ω (<i>power off</i>)
<i>Input leakage current</i>		± 20 nA
	<i>Input voltage > ± 30 V (power on/off)</i>	± 1 μ A maximum
Input capacitance		590 pF
Maximum working voltage (signal + common mode)	Voltage mode: ± 20 V range	± 20.01 V maximum
	Voltage mode: all other voltage input ranges	± 10.25 V maximum
Crosstalk	Adjacent channels	100 dB
Input coupling		DC
Warm-up time		15 minutes minimum
Open thermocouple detect		Automatically enabled when the channel is configured for a thermocouple sensor.

CJC sensor accuracy	15 °C to 35 °C	± 0.15 °C typical
	0 °C to 55 °C	± 0.5 °C maximum

Channel configurations

Table 3. Channel configurations

Channel	Category	Conditions	Specification
CxH/CxL	Thermocouple The AI-EXP32 GND and DGND pins are isolated from earth ground. You can connect thermocouple sensors to voltages referenced to earth ground as long as isolation between the GND/DGND pins and earth ground is maintained. Unused input channels can be left floating or tied to GND (pins 17, 18, 49, 50).		16 differential channels
CxH/CxL	Voltage When connecting differential voltage inputs to a floating voltage source, the user must provide a DC return path from each voltage input to ground. To do this, connect a resistor from each input to a GND pin (pins 17, 18, 49, 50). A value of approximately 100 k Ω can be used for most applications.		16 differential channels
CxH/CxL	Voltage		32 single-ended channels

Compatible sensors

Table 4. Compatible sensor type specifications

Parameter	Conditions
Thermocouple	J: -210 °C to 1200 °C
	K: -270 °C to 1372 °C
	R: -50 °C to 1768 °C
	S: -50 °C to 1768 °C
	T: -270 °C to 400 °C
	N: -270 °C to 1300 °C
	E: -270 °C to 1000 °C
B: 0 °C to 1820 °C	

Accuracy

Thermocouple measurement accuracy

The AI-EXP32 is a multiplexer-based channel expansion module that increases the number of thermocouple input channels of a USB-2416 series host module. For thermocouple accuracy information, refer to the electrical specification of the particular USB-2416 host module that is interfacing with the AI-EXP32.

There is a CJC sensor for each terminal block of the module. The thermocouple measurement accuracy assumes that the screw terminals are at the same temperature as the CJC sensor.

Connect thermocouples to the AI-EXP32 such that they are floating with respect to GND (pins 17, 18, 49, 50).

When configuring thermocouple sensors, keep any stray capacitance relative to GND (pins 17, 18, 49, 50) as small as possible to avoid settling time and accuracy errors.

Analog input DC voltage measurement accuracy:

The AI-EXP32 is a multiplexer-based channel expansion module that increases the number of voltage input channels of a USB-2416 series host module. For voltage accuracy information, refer to the electrical specification of the USB-2416 host device that is the interface to the AI-EXP32 interface.

Digital input/output

Table 5. Digital input specifications

Number of I/O	16 channels
Configuration	Each DIO bit can be independently read from (DIN) or written to (DOUT). The DIN bits can be read at any time whether the DOUT is active or tri-stated.
Input voltage range	0 to +15 V
Input type	CMOS (Schmitt trigger)
Input characteristics	47 k Ω pull-up/pull-down resistor, 28 k Ω series resistor
<i>Maximum input voltage range</i>	<i>0 to +20 V maximum (power on/off, relative to DGND pins 29,30,61,62)</i>
Pull-up/pull-down configuration	All pins pulled up to +5 V via individual 47 k Ω resistors. <ul style="list-style-type: none"> ■ The JP1 (DIO 8- 15) shorting block default position is pull-up or "HI." ■ The JP2 (DIO 16- 23) shorting block default position is pull-up or "HI." Pull down capability is available by placing either of the JP1 and JP2 shorting blocks in the "LO" position.
Transfer rate (software paced)	500 port reads or single-bit reads per second, typical.
Input high voltage	1.3 V minimum, 2.2 V maximum
Input low voltage	1.5 V maximum, 0.6 V minimum
Schmitt trigger hysteresis	0.4 V minimum, 1.2 V maximum

Note 1: DGND pins (pins 29, 30, 61, 62) are recommended for use with digital input and digital output pins. The DGND and GND pins are common and are isolated from earth ground.

Table 6. Digital output specifications

Number of I/O	16 channels
Configuration	Each DIO bit can be independently read from (DIN) or written to (DOUT). The DIN bits may be read at any time whether the DOUT is active or tri-stated
Output characteristics	47 k Ω pull-up, open drain (DMOS transistor)
Pull-up configuration	All pins pulled up to +5 V via individual 47 k Ω resistors. <ul style="list-style-type: none"> ■ The JP1 (DIO 8- 15) shorting block default position is pull-up or "HI." ■ The JP2 (DIO 16- 23) shorting block default position is pull-up or "HI."
Transfer rate (software paced)	Digital output – 500 port writes or single-bit writes per second typical.
Output voltage range	<ul style="list-style-type: none"> ■ 0 to +5 V (no external pull up resistor, internal 47 kΩ pull-up resistors connected to +5 V by default) ■ 0 to +15 V maximum (Note 4)
Drain to source breakdown voltage	+50 V minimum
Off state leakage current (Note 5)	0.1 μ A
Sink current capability	<ul style="list-style-type: none"> ■ 150 mA maximum (continuous) per output pin ■ 150 mA maximum (continuous) for all eight channels
DMOS transistor on-resistance (drain to source)	4 Ω

Note 2: Each DMOS transistor's source pin is internally connected to GND.

Note 3: DGND pins (pins 29, 30, 61, 62) are recommended for use with digital input and digital output pins. The DGND and GND pins are common and are isolated from earth ground.

Note 4: The external pull-up is connected to the digital output bit through an external pull-up resistor. Adding an external pull-up resistor connects it in parallel with the internal 47k Ω pull-up resistor of that particular digital input/output bit. Careful consideration should be made when considering the external pull-up resistor value and the resultant pull-up voltage produced at the load.

Note 5: Does not include the additional leakage current contribution that may occur when using an external pull-up resistor.

Power

Table 7. Power specifications

Parameter	Conditions	Specification
+5VUSER output voltage range	Available at terminal block pin 19	4.9 V minimum to 5.1 V maximum
User +5VUSER output current	Available at terminal block pin 19	10 mA maximum

Environmental

Table 8. Environmental specifications

Operating temperature range	0 to 50° C maximum
Storage temperature range	-40 to 85 ° C maximum
Humidity	0 to 90% non-condensing maximum

Mechanical

Table 9. Mechanical specifications

Dimensions	245 mm (L) x 146 mm (W) x 50 mm (H)
------------	-------------------------------------

Screw terminal connector type and pin-out

Table 10. Screw terminal connector specifications

Connector type	Detachable screw terminal
Wire gauge range	16 AWG to 30 AWG

Expansion port

The AI-EXP32 expansion port is intended to interface the AI-EXP32 to a USB-2416 series product. Do not use any of the expansion port pins for any other purpose.

Table 11. AI-EXP32 37-pin connector pin out

Pin	Signal name	Pin description
1	GND	Analog ground
2	NC	No connect
3	GND	Analog ground
4	NC	No connect
5	GND	Analog ground
6	VCC	+12 V power
7	NC	No connect
8	NC	No connect
9	IM_A2	I/O control signal
10	IM_A1	I/O control signal
11	IM_A0	I/O control signal
12	IMEN10	I/O control signal
13	IMEN9	I/O control signal
14	IMEN8	I/O control signal
15	IMEN7	I/O control signal
16	DIO_LOAD2	I/O control signal
17	DIO_LOAD1	I/O control signal
18	NC	No connect
19	NC	No connect
20	+3.3V_ISO	+3.3 V power
21	GND	Analog ground
22	+5 VA	+5 V analog power
23	+20.5V	+20.5 V power
24	GND	Analog ground
25	-20.5V	-20.5 V power
26	VDD_ISO	+5 V digital power
27	EXTDIO_INT	I/O control signal
28	CM_A3	I/O control signal
29	SM_A1	I/O control signal
30	SM_AO	I/O control signal
31	CM_A2	I/O control signal
32	SCL	Serial I/O control signal
33	SDA	Serial I/O control signal
34	MOSI	Serial I/O control signal
35	SCK	Serial I/O control signal
36	NC	No connect
37	NC	No connect

Table 12. 16-channel differential mode pin out

Pin	Signal name	Pin description	Pin	Signal name	Pin description
1	CH16H	Channel 16 HI	33	CH31L	Channel 31 LO
2	CH16L	Channel 16 LO	34	CH31H	Channel 31 HI
3	CH17H	Channel 17 HI	35	CH30L	Channel 30 LO
4	CH17L	Channel 17 LO	36	CH30H	Channel 30 HI
5	CH18H	Channel 18 HI	37	CH29L	Channel 29 LO
6	CH18L	Channel 18 LO	38	CH29H	Channel 29 HI
7	CH19H	Channel 19 HI	39	CH28L	Channel 28 LO
8	CH19L	Channel 19 LO	40	CH28H	Channel 28 HI
9	CH20H	Channel 20 HI	41	CH27L	Channel 27 LO
10	CH20L	Channel 20 LO	42	CH27H	Channel 27 HI
11	CH21H	Channel 21 HI	43	CH26L	Channel 26 LO
12	CH21L	Channel 21 LO	44	CH26H	Channel 26 HI
13	CH22H	Channel 22 HI	45	CH25L	Channel 25 LO
14	CH22L	Channel 22 LO	46	CH25H	Channel 25 HI
15	CH23H	Channel 23 HI	47	CH24L	Channel 24 LO
16	CH23L	Channel 23 LO	48	CH24H	Channel 24 HI
17	GND	Analog ground	49	GND	Analog ground
18	GND	Analog ground	50	GND	Analog ground
19	+5VUSER	+5 V output	51	NC	No connect
20	NC	No connect	52	NC	No connect
21	DIO8	Digital input/output	53	DIO23	Digital input/output
22	DIO9	Digital input/output	54	DIO22	Digital input/output
23	DIO10	Digital input/output	55	DIO21	Digital input/output
24	DIO11	Digital input/output	56	DIO20	Digital input/output
25	DIO12	Digital input/output	57	DIO19	Digital input/output
26	DIO13	Digital input/output	58	DIO18	Digital input/output
27	DIO14	Digital input/output	59	DIO17	Digital input/output
28	DIO15	Digital input/output	60	DIO16	Digital input/output
29	DGND	Digital ground	61	DGND	Digital ground
30	DGND	Digital ground	62	DGND	Digital ground
31	NC	No connect	63	NC	No connect
32	NC	No connect	64	NC	No connect

Do not connect to terminal block pins labeled "NC."

Table 13. 32-channel single-ended mode pin out

Pin	Signal name	Pin description	Pin	Signal name	Pin description
1	CH16H	Channel 16	33	CH31L	Channel 63
2	CH16L	Channel 48	34	CH31H	Channel 31
3	CH17H	Channel 17	35	CH30L	Channel 62
4	CH17L	Channel 49	36	CH30H	Channel 30
5	CH18H	Channel 18	37	CH29L	Channel 61
6	CH18L	Channel 50	38	CH29H	Channel 29
7	CH19H	Channel 19	39	CH28L	Channel 60
8	CH19L	Channel 51	40	CH28H	Channel 28
9	CH20H	Channel 20	41	CH27L	Channel 59
10	CH20L	Channel 52	42	CH27H	Channel 27
11	CH21H	Channel 21	43	CH26L	Channel 58
12	CH21L	Channel 53	44	CH26H	Channel 26
13	CH22H	Channel 22	45	CH25L	Channel 57
14	CH22L	Channel 54	46	CH25H	Channel 25
15	CH23H	Channel 23	47	CH24L	Channel 56
16	CH23L	Channel 55	48	CH24H	Channel 24
17	GND	Analog ground	49	GND	Analog ground
18	GND	Analog ground	50	GND	Analog ground
19	+5VUSER	+5V output	51	NC	No connect
20	NC	No connect	52	NC	No connect
21	DIO8	Digital input/output	53	DIO23	Digital input/output
22	DIO9	Digital input/output	54	DIO22	Digital input/output
23	DIO10	Digital input/output	55	DIO21	Digital input/output
24	DIO11	Digital input/output	56	DIO20	Digital input/output
25	DIO12	Digital input/output	57	DIO19	Digital input/output
26	DIO13	Digital input/output	58	DIO18	Digital input/output
27	DIO14	Digital input/output	59	DIO17	Digital input/output
28	DIO15	Digital input/output	60	DIO16	Digital input/output
29	DGND	Digital ground	61	DGND	Digital ground
30	DGND	Digital ground	62	DGND	Digital ground
31	NC	No connect	63	NC	No connect
32	NC	No connect	64	NC	No connect

Do not connect to terminal block pins labeled "NC."

CE Declaration of Conformity

Manufacturer: Measurement Computing Corporation
Address: 10 Commerce Way
Suite 1008
Norton, MA 02766
USA

Category: Electrical equipment for measurement, control and laboratory use.

Measurement Computing Corporation declares under sole responsibility that the product

AI-EXP32

to which this declaration relates is in conformity with the relevant provisions of the following standards or other documents:

EC EMC Directive 2004/108/EC: General Requirements, EN 61326-1:2006 (IEC 61326-1:2005).

Emissions:

- EN 55011 (2007) / CISPR 11(2003): Radiated emissions: Group 1, Class A
- EN 55011 (2007) / CISPR 11(2003): Conducted emissions: Group 1, Class A

Immunity: EN 61326-1:2006, Table 3.

- IEC 61000-4-2 (2001): Electrostatic Discharge immunity.
- IEC 61000-4-3 (2002): Radiated Electromagnetic Field immunity.
- IEC 61000-4-4 (2004): Electric Fast Transient Burst Immunity.
- IEC 61000-4-5 (2001): Surge Immunity.
- IEC 61000-4-6 (2003): Radio Frequency Common Mode Immunity.
- IEC 61000-4-11 (2004): Voltage Interrupts.
-
- To maintain compliance to the standards of this declaration, the following conditions must be met.
-
- The host computer, peripheral equipment, power sources, and expansion hardware must be CE compliant.
- All I/O cables must be shielded, with the shields connected to ground.
- I/O cables must be less than 3 meters (9.75 feet) in length.
- The host computer must be properly grounded.
- Equipment must be operated in a controlled electromagnetic environment as defined by Standards EN 61326-1:2006, or IEC 61326-1:2005.
-

Declaration of Conformity based on tests conducted by Chomerics Test Services, Woburn, MA 01801, USA in July, 2008. Test records are outlined in Chomerics Test Report #EMI5075.08. Further testing was conducted by Chomerics Test Services, Woburn, MA. 01801, USA in February, 2009. Test records are outlined in Chomerics Test report #EMI5271.09.

We hereby declare that the equipment specified conforms to the above Directives and Standards.



Carl Haapaoja, Director of Quality Assurance

Measurement Computing Corporation
10 Commerce Way
Suite 1008
Norton, Massachusetts 02766
(508) 946-5100
Fax: (508) 946-9500
E-mail: info@mccdaq.com
www.mccdaq.com