

TC-32 and TC-32-EXP

USB/Ethernet-Based High-Precision Thermocouple Measurement Devices



A TC-32 connected to a TC-32-EXP device provides up to 64 TC inputs, 16 digital inputs, and 64 digital outputs which can be configured as alarms. All DIO channels are isolated.

Features

- USB and 10/100 Ethernet interface
- 32 differential thermocouple (TC) inputs
 - Expandable to 64 TC inputs with TC-32-EXP expansion device
 - TC channel-to-host isolation
- Easy-to-connect mini-jack connectors
- 24-bit resolution
- 3 S/s per channel sample rate
- Supports J, K, R, S, T, N, E, and B type thermocouples (software-selectable per channel)
- Per channel out-of-range alarm configuration
- Cold-junction compensation (CJC) sensor per channel
- Open thermocouple detection
- 8 digital inputs and 32 digital outputs/alarms.
 - Expandable to 16 digital inputs, and 64 digital outputs/alarms with TC-32-EXP expansion device
 - Isolated from TC inputs and host
 - 50-pin header connector (cable sold separately)
- 19" rack mountable
- Requires external power (power adapter included with TC-32)
 - TC-32-EXP is powered by connected TC-32

Supported Operating Systems

- Windows 10/8/7/Vista® 32/64-bit
- Android™

Overview

The TC-32 and TC-32-EXP offer exceptional performance and accuracy for thermocouple (TC) measurement applications at a low cost per channel. Offering both Ethernet and USB ports, the TC-32 provides 32 channels of 24-bit resolution for medium channel installations.

The TC-32-EXP adds 32 high-precision channels to support larger installations.

Accuracy is designed into the product with sigma-delta 24-bit ADCs, differential inputs, TC-to-host isolation and cold-junction compensation (CJC) for each channel to reduce the effects of thermal gradients.

With digital alarming notifications when a temperature exceeds programmed limits, the TC-32 and TC-32-EXP offer the perfect solution for temperature monitoring applications including server rooms, refrigerated storage, and long-run test cells.

Channel Expansion with the TC-32-EXP

Connect a TC-32-EXP expansion device to double the number of TC inputs (64), digital inputs (16), and digital outputs/alarms (64).

The TC-32-EXP connects to the host TC-32 through a 40-pin expansion connector. The host TC-32 provides all power to the TC-32-EXP

The TC-32-EXP supports all of the TC input and digital I/O features of the host TC-32, including built-in cold-junction compensation and open thermocouple detection.

USB or Ethernet Interface

The TC-32 can communicate with a host device through either USB or 10/100 Ethernet. By offering both USB and Ethernet ports, the TC-32 is the perfect solution for local or remote monitoring.

TC Input

Connect up to 32 differential TC input channels using the four groups of eight mini-jack connectors on the front panel of each device.

Both the TC-32 and TC-32-EXP support sample rates up to 3 S/s and TC types J, K, R, S, T, N, E, and B. TC types are software-selectable per channel.

Cold-Junction Compensation (CJC)

Each TC input on TC-32 devices has a high-resolution CJC sensor that provides a local cold-junction temperature reference point. This feature ensures the highest level of temperature measurement accuracy.

TC-32 and TC-32-EXP

General Information



Data Linearization

After the device performs CJC correction, an onboard microcontroller automatically linearizes the TC data using National Institute of Standards and Technology (NIST) linearization coefficients for the selected TC type.

The data is then output as a 32-bit floating point value in the configured format (voltage or temperature).

Open-Thermocouple Detection (OTD)

TC-32 devices are equipped with OTD for all TC input channels. When enabled, OTD allows users to monitor their TCs and determine if they are broken or disconnected.

Connecting TCs to Common-Mode Voltage Sources

Thermocouple inputs are isolated and thermocouple common-mode voltage may deviate up to 48 VDC or 3.5 VAC (at 60 Hz) from chassis ground without any negative impact to measurement accuracy. Common-mode voltages between channels, however, should not vary more than ± 1.4 VDC (refer to [Common mode voltage range](#) specifications on page 4 for more information).

Digital I/O and Alarms

The TC-32 provides up to 8 digital inputs and 32 digital outputs that are electrically isolated from the host device and from the TC-32 analog circuits. This configuration allows users to enable a digital output/ alarm for each TC channel.



The TC-32 can connect to an Ethernet or USB port. Both the TC-32 and TC-32-EXP include 50-pin connectors that provide access to all DIO channels. Adding the TC-32-EXP expansion device doubles the channel count of the system.

When an alarm is enabled, its associated output line is driven to the appropriate state determined by the alarm options and input temperature. The alarm configurations are stored in non-volatile memory and loaded at power up. TC-32 input channels are constantly converted on enabled channels and processed for alarm conditions regardless of communications connectivity ensuring proper alarming even if communication to the device is lost.

Alarm outputs can be used to indicate when a temperature threshold has been exceeded. This output can be connected to another device, such as a physical alarm or control system.

Each digital output is open-drain, which can sink up to 100 mA for direct drive applications.

The TC-32-EXP provides an additional 8 digital inputs and 32 digital outputs.

Digital I/O signals and alarms are accessible through a 50-pin connector on both the TC-32 and TC-32-EXP.

Power

The TC-32 requires external power. A 5 V, 10 W power adapter (PS-5V2AEPS) is included with the TC-32.

The TC-32 provides power to the TC-32-EXP when they are connected.

Calibration

Both the TC-32 and TC-32-EXP are factory-calibrated using a NIST-traceable calibration process. Specifications are guaranteed for one year. For calibration beyond one year, return the device to the factory for recalibration.

The TC-32 and TC-32-EXP devices also support field calibration so that users can calibrate a device locally.



TC-32 and TC-32-EXP

Software



Software Support

The TC-32 and TC-32-EXP are supported by the software in the table below.

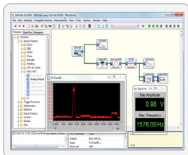
Ready-to-Run Applications	
DAQami	 <p>Advanced data logging application with drag-and-drop software interface that is used to acquire, view, and log data. DAQami can be configured to log analog, digital, and counter channels, and to view that data in real-time or post-acquisition on user-configurable displays. Windows OS</p> <p>DAQami is available as a purchased software download.</p>
InstaCal	 <p>An interactive installation, configuration, and test utility for MCC hardware. Windows OS</p> <p>InstaCal is included with the free MCC DAQ Software bundle (CD/download).</p>
TracerDAQ and TracerDAQ Pro	 <p>Virtual strip chart, oscilloscope, function generator, and rate generator applications used to generate, acquire, analyze, display, and export data. The Pro version provides enhanced features. Windows OS</p> <p>TracerDAQ is included with the free MCC DAQ Software bundle (CD/download).</p> <p>TracerDAQ Pro is available as a purchased software download.</p>
General-Purpose Programming Support	
Universal Library (UL)	 <p>Programming library of function calls for C, C++, VB, C# .Net, and VB .Net using Visual Studio and other IDEs. Windows OS</p> <p>The UL is included with the free MCC DAQ Software bundle (CD/download).</p>
UL for Android	 <p>Programming library of function calls for Java programmers who develop apps for Android-based tablets and phones. UL for Android communicates with select MCCDAQ devices. Supports Android project development on Windows, Linux, Mac OS X.</p> <p>UL for Android is included with the free MCC DAQ Software bundle (CD/download).</p>
Application-Specific Programming Support	
ULx for NI LabVIEW	 <p>A comprehensive library of VIs and example programs for NI LabVIEW that is used to develop custom applications that interact with most MCC devices. Windows OS</p> <p>ULx for NI LabVIEW is included with the free MCC DAQ Software bundle (CD/download).</p>
DASYLab	 <p>Icon-based data acquisition, graphics, control, and analysis software that allows users to create complex applications in minimal time without text-based programming.</p> <p>DASYLab is available as a purchased software download. Windows OS</p>

TC-32 and TC-32-EXP

Specifications

TC-32 and TC-32-EXP Block Diagram

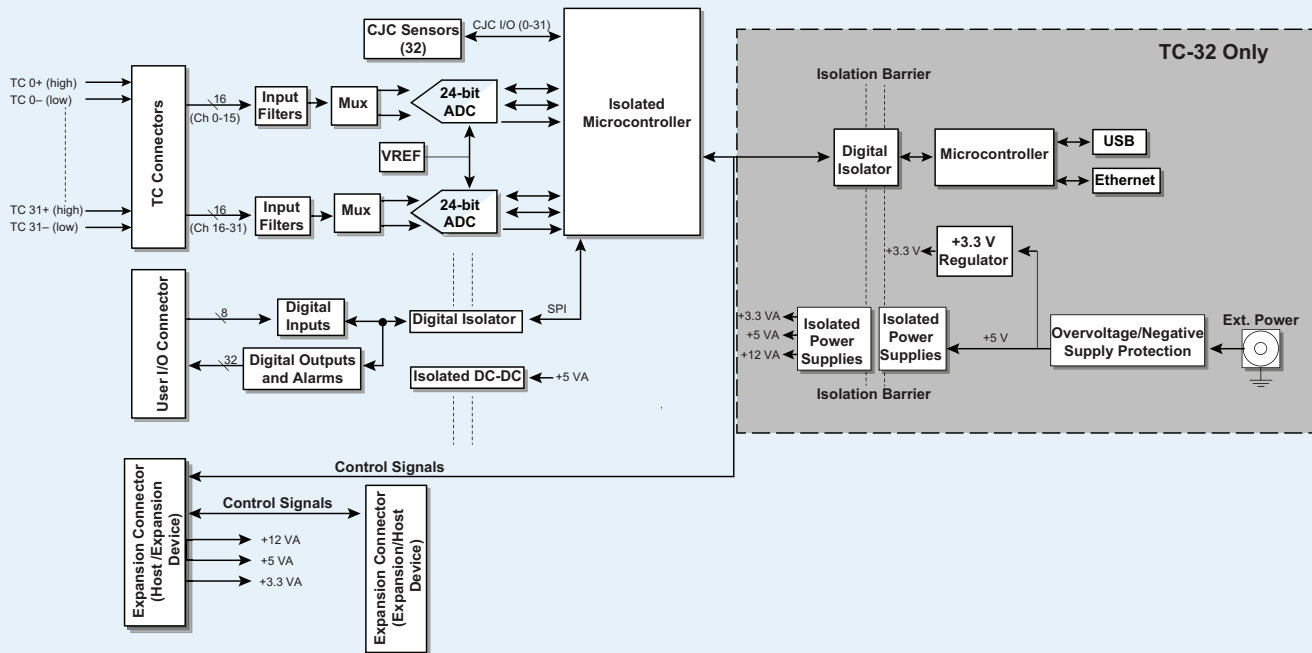

Specifications

All specifications are subject to change without notice.
Typical for 25 °C unless otherwise specified.
These specifications apply to both the TC-32 and TC-32-EXP unless noted otherwise.

Thermocouple Input

A/D converter type: Delta-Sigma
A/D resolution: 24-bit
Number of channels: 32 (64 when TC-32 connected to TC-32-EXP)
Filtering options: 50 Hz or 60 Hz noise filtering, software-selectable
Isolation between any TC input channel and chassis ground: 500 VDC absolute max
Channel configuration: Software-selectable to match TC sensor type
Differential input voltage range: ± 78.125 mV
Absolute maximum input voltage (between any two TCx inputs): ± 25 V (power on), ± 25 V (power off)
Differential input impedance
50 Hz filtering, power on: 26 M Ω
60 Hz filtering, power on: 20 M Ω
Input current
Open thermocouple detect disabled: 2 nA
Open thermocouple detect enabled: 75 nA
Common mode rejection
50 Hz filtering, at DC and $f_{in}=50$ Hz: 110 dB
60 Hz filtering at DC and $f_{in}=60$ Hz: 110 dB
Noise rejection
50 Hz filtering at $f_{in}=50$ Hz: 80 dB typ
60 Hz filtering at $f_{in}=60$ Hz: 80 dB typ
Input bandwidth
50 Hz filtering: 22 Hz
60 Hz filtering: 26 Hz
Crosstalk between any two TC inputs: -90 dB
Sample rate: 3 Hz min (per channel)
The enabled thermocouple inputs are continuously converted at the maximum A/D converter rate.

Common mode voltage range

TCx channel to TCx channel: ± 1.40 V
TCx channel relative to chassis ground,
 $f_{in} = 60$ Hz: ± 3.5 VAC p-p
TCx channel relative to chassis ground: ± 48 V DC
When thermocouple sensors are connected to different common mode voltages, the channels with floating thermocouples sensors are biased to approximately the average value of the applied common mode voltages. Each of the applied common mode voltages must then be less than or equal to the average common mode voltage ± 1.40 V or $[CMV_{applied} \leq (CMV_{average} \pm 1.4$ V)].
Input noise (50 Hz or 60 Hz filtering): 510 nV rms
Gain error: 50 Hz or 60 Hz filtering: 0.004 % FSR
Offset error: 50 Hz or 60 Hz filtering: 3 μ V
Measurement sensitivity (smallest change in temperature that can be detected)
Thermocouple type J,K,T,E,N: 0.07 °C
Thermocouple type R,S: 0.18 °C
Thermocouple type B: 0.60 °C
Warm-up time: 20 minutes min
Open thermocouple detect response time: 1 s
CJC sensor accuracy (0 °C to 45 °C): ± 0.20 °C typ, ± 0.40 °C max

Channel Configuration

Thermocouple (J, K, S, R, B, E, T, N): 32 differential channels
Channel configuration is stored on EEPROM external to the isolated microcontroller by the firmware whenever any item is modified. Modification is performed by commands issued from an external application, and the configuration is made non-volatile through the use of the EEPROM.

Compatible Thermocouple Sensors

Thermocouple

J: -210 °C to 1200 °C	B: 0 °C to 1820 °C
K: -270 °C to 1372 °C	E: -270 °C to 1000 °C
S: -50 °C to 1768 °C	T: -270 °C to 400 °C
R: -50 °C to 1768 °C	N: -270 °C to 1300 °C

TC-32 and TC-32-EXP

Specifications



Accuracy

Thermocouple measurement accuracy specifications include polynomial linearization, cold-junction compensation, and system noise. The accuracy specifications assume the device is operated within its enclosure and with the enclosure in a horizontal, upright orientation.

The device should also be warmed up for the recommended 20 minutes. If the maximum digital output load of 3.2 amps is applied, add an additional 0.30 °C to the typical and maximum accuracy specifications listed below.

Errors shown do not include inherent thermocouple error. Contact your thermocouple supplier for details on the actual thermocouple accuracy error.

Thermocouple Measurement Accuracy, Including CJC Measurement Error					
All Specifications are (±)					
Sensor Type	Sensor Temperature	Accuracy Error			
		Maximum, 15 °C to 35 °C	Typical, 15 °C to 35 °C	Maximum, 0 °C to 45 °C	Typical, 0 °C to 45 °C
J	-210 °C	1.965 °C	0.910 °C	2.167 °C	0.989 °C
	0	0.787 °C	0.361 °C	0.816 °C	0.375 °C
	1200 °C	0.752 °C	0.371 °C	1.148 °C	0.508 °C
K	-210 °C	2.295 °C	1.061 °C	2.520 °C	1.152 °C
	0	0.821 °C	0.376 °C	0.852 °C	0.392 °C
	1372 °C	1.029 °C	0.504 °C	1.560 °C	0.688 °C
S	-50	2.467 °C	1.111 °C	2.655 °C	1.223 °C
	250 °C	1.835 °C	0.825 °C	1.961 °C	0.904 °C
	1768 °C	0.893 °C	0.361 °C	1.519 °C	0.590 °C
R	-50	2.609 °C	1.174 °C	2.810 °C	1.293 °C
	250 °C	1.862 °C	0.837 °C	1.992 °C	0.918 °C
	1768 °C	0.754 °C	0.305 °C	1.346 °C	0.520 °C
B	250 °C	2.450 °C	1.090 °C	2.707 °C	1.254 °C
	700 °C	0.937 °C	0.424 °C	1.136 °C	0.520 °C
	1820 °C	0.610 °C	0.300 °C	1.056 °C	0.467 °C
E	-200 °C	1.754 °C	0.811 °C	1.933 °C	0.880 °C
	0	0.775 °C	0.355 °C	0.806 °C	0.369 °C
	1000 °C	0.657 °C	0.323 °C	0.989 °C	0.437 °C
T	-200 °C	2.005 °C	0.923 °C	2.207 °C	1.005 °C
	0	0.836 °C	0.382 °C	0.874 °C	0.400 °C
	400 °C	0.544 °C	0.255 °C	0.659 °C	0.297 °C
N	-200 °C	2.255 °C	1.038 °C	2.481 °C	1.134 °C
	0	0.908 °C	0.415 °C	0.949 °C	0.437 °C
	1300 °C	0.718 °C	0.357 °C	1.157 °C	0.510 °C

Digital Input

Number of inputs: 8 channels (16 when TC-32 connected to TC-32-EXP)

Configuration: Fixed input

Input voltage range: 0 V to +15 V

Input type: CMOS (Schmitt trigger)

Input characteristics: 100 kΩ pull-up resistor, 28.7 kΩ series resistor

Maximum input voltage range: 0 V to +20 V max (power on/off, relative to IGND pins)

Pull-up configuration: All pins pulled up to +5 V via individual 100 kΩ resistors using slide switch SW5. SW5 default position are on (pulled up).

Transfer rate (software paced): 500 port reads per second typ

Input high voltage: 1.3 V min, 2.2 V max

Input low voltage: 1.5 V max, 0.6 V min

Schmitt trigger hysteresis: 0.4 V min, 1.2 V max

Digital Output

Number of outputs: 32 channels, shared with alarms (64 when TC-32 connected to TC-32-EXP)

Configuration: Open drain output

Output characteristics: 100 kΩ pull-up, open drain (DMOS transistor)

Pull-up configuration: All pins pulled up to +5 V through individual 100 kΩ resistors using slide switches SW1-SW4. The default positions for SW1-SW4 are on (pulled up.)

Transfer rate (software paced): Digital output – 500 port writes per second typ.

Output voltage range

0 V to +5 V (internal 100 kΩ pull-up resistors connected to +5 V by default)

0 V to +15 V max (using external pull-up resistor)

Ground pins labeled IGND are isolated from AGND and chassis ground.

Off state leakage current: 0.1 μA

Sink current capability: 100 mA max (continuous) per output pin

DMOS transistor on-resistance (drain to source): 4 Ω

Temperature Alarms

Number of alarms: 32, shared with digital output

Alarm functionality: Each alarm controls its associated digital output line as an alarm output. When an alarm is enabled, its associated output line is driven to the appropriate state determined by the alarm options and input temperature. The alarm configurations are stored in non-volatile memory and loaded at power on.

Alarm input modes (T1 and T2 can be independently set for each alarm)

Alarm when input temperature ≥ T1, reset alarm when input temperature < T2

Alarm when input temperature ≤ T1, reset alarm when input temperature > T2

Alarm when input temperature is < T1 or > T2

Alarm error modes

Alarm on temperature reading only

Alarm on temperature reading, open thermocouple, or common-mode voltage error

Alarm on open thermocouple or common-mode voltage error only

Alarm output modes

Disabled, digital output line may be used for normal operation

Enabled, active high output (output line goes high when alarm condition is met)

Enabled, active low output (output line goes low when alarm condition is met)

Alarm output may be latched and will not clear unless explicitly cleared by the user

Alarm latency: 1 second, max

Alarm settings are applied when changed and at power-on. Temperatures are constantly converted on enabled channels and processed for alarm conditions regardless of the communications connectivity.

Memory

EEPROM: 4,096 bytes

Microcontroller

Type: One high-performance 32-bit RISC microcontroller

TC-32 and TC-32-EXP

Specifications



USB (TC-32 Only)

Device type: USB 2.0 full speed
Device compatibility: USB 1.1, USB 2.0, USB 3.0
Connector: Standard B
Cable length: 5 meters max
Power: Self-powered (no USB current consumed)

Network (TC-32 Only)

Ethernet Connection

Ethernet type: 100 Base-TX, 0 Base-T
Communication rates: 10/100 Mbps, auto-negotiated
Connector: RJ-45, 8 position
Cable length: 100 meters max
Additional parameters: HP Auto-MDIX support

Network Interface

Protocols used: TCP/IP (IPv4 only), UDP
Network ports used: UDP: 54211 (discovery)
TCP: 54211 (commands)
Network IP configuration: DHCP + link-local, DHCP, static, link-local
Network name: TC-32-xxxxxx, where xxxxxx are the lower 6 digits of the device MAC address
Network name publication: By NBNS (responds to b-node broadcasts, therefore only available on the local subnet)

Network Factory Default Settings

Factory default IP address: 192.168.0.101
Factory default subnet mask: 255.255.255.0
Factory default gateway: 192.168.0.1
Factory default DHCP setting: DHCP + link-local enabled

Network Security

Security implementation: TCP sockets are not opened unless application sends the correct PIN code (stored in non-volatile memory, may be changed by user, default value 0000)
Number of concurrent sessions: 1
Vulnerabilities: TCP Sequence Number Approximation Vulnerability

Power (TC-32 Only)

Supply current: 330 mA typ, 610 mA max;
550 mA typ, 1000 mA max (with TC-32-EXP connected)
External power input: +5 VDC \pm 5% (+5 VDC power supply provided)
Voltage specification applies at barrel plug power input. The power supply provided with the device meets this specification at the rated total power supply current. If a different power supply is used, small line resistances could cause significant voltage drop between the power supply and the barrel plug input.
Power switch: Rocker type
External power supply (included)
MCC p/n PS-5V2AEPS: +5 VDC, 10 W, 5% regulation
External power input voltage supervisor limits
4.0 V > Vext > 5.75 V: PWR LED = Off (power fault)
4.0 V < Vext < 5.75 V: PWR LED = On
Chassis ground connection: 6-32 screw on rear of enclosure

LED Displays and the Factory Reset Button

POWER LED (top): Indicates power on. Blinks when blink command is sent. Both the POWER and ACTIVITY LEDs blink in firmware upgrade mode.
ACTIVITY LED: On when there is a valid connection and blinks when a command is sent to the TC-32-EXP. Both the POWER and ACTIVITY LEDs blink in firmware upgrade mode.
ALARM LED: Indicates that an alarm condition is met.
OPEN TC LED (bottom): Indicates that there is an open thermocouple condition.
Factory reset button: When held for 3 seconds, the LEDs turn off for a short time, indicating a reset is in process. When the LEDs turn back on, reset is complete and the factory-default network settings are restored.

Environment

Operating temperature range: 0 °C to 45 °C
Storage temperature range: -40 °C to 85 °C
Humidity: 0 °C to 90% non-condensing

Mechanical

Dimensions (L x W x H): 482.6 x 128.6 x 43.18 mm (19 x 6.15 x 1.74 in.)

Signal I/O Connectors

User accessible I/O connectors (excluding USB and Ethernet): Thermocouple inputs, digital I/O connector, expansion connector, chassis ground
Thermocouple connector type: Thermocouple Mini-Jack (Omega PCC-SMP-V-U-100)
Digital I/O connector type: 50-pin IDC header
Compatible cable for the 50-pin DIO connector: C50FF-x
Compatible accessory products with the C50FF-x cable: CIO-MINI50, SCB-50
Expansion connector type: 40-pin IDC header
Compatible cables for the 40-pin expansion connector: C40FF-x
Chassis ground connector: 6-32 screw

TC-32 and TC-32-EXP

Ordering



Ordering Information

Part No.	Description
TC-32	USB- or Ethernet-based 24-bit, 32-channel thermocouple input device with 8 digital inputs and 32 digital outputs/alarms. Includes USB cable, Ethernet cable, power supply, and MCC DAQ software CD.
TC-32-EXP	24-bit, 32-channel thermocouple input expansion device for TC-32 with 8 digital inputs and 32 digital outputs/alarms. Includes 40-pin expansion cable for connection to host TC-32.

Accessories and Cables

Part No.	Description
C40FF-x	40-conductor ribbon cable, female to female; x is the length in feet. Replacement expansion cable.
C50FF-x	50-conductor ribbon cable, female to female; x is the length in feet. Use for DIO connections.
CIO-MINI50	50-pin universal screw-terminal board.
SCB-50	50-pin signal connection box.
PS-5V2AEPS	Replacement power supply for TC-32 – interchangeable plugs available separately

Sensors (Sold Separately)

Part No.	Description
CN-144-JM	Type J male thermocouple connector
CN-144-KM	Type K male thermocouple connector
CN-144-TM	Type T male thermocouple connector
745690-J001	J-type thermocouple wire, fiberglass (0 °C to 482 °C, 32 °F to 900 °F) 1 m
745690-J002	J-type thermocouple wire, fiberglass (0 °C to 482 °C, 32 °F to 900 °F) 2 m
745690-K001	K-type thermocouple wire, fiberglass (0 °C to 482 °C, 32 °F to 900 °F) 1 m
745690-K002	K-type thermocouple wire, fiberglass (0 °C to 482 °C, 32 °F to 900 °F) 2 m
745690-T001	T-type thermocouple wire, fiberglass (0 °C to 260 °C, 32 °F to 500 °F) 1 m
745690-T002	T-type thermocouple wire, fiberglass (0 °C to 260 °C, 32 °F to 500 °F) 2 m



Software also Available from MCC

Part No.	Description
DAQami	Easy-to-use advanced data logging software to acquire, view, and log data
TracerDAQ Pro	Out-of-the-box virtual instrument suite with strip chart, oscilloscope, function generator, and rate generator – professional version
DASYLab	Icon-based data acquisition, graphics, control, and analysis software