

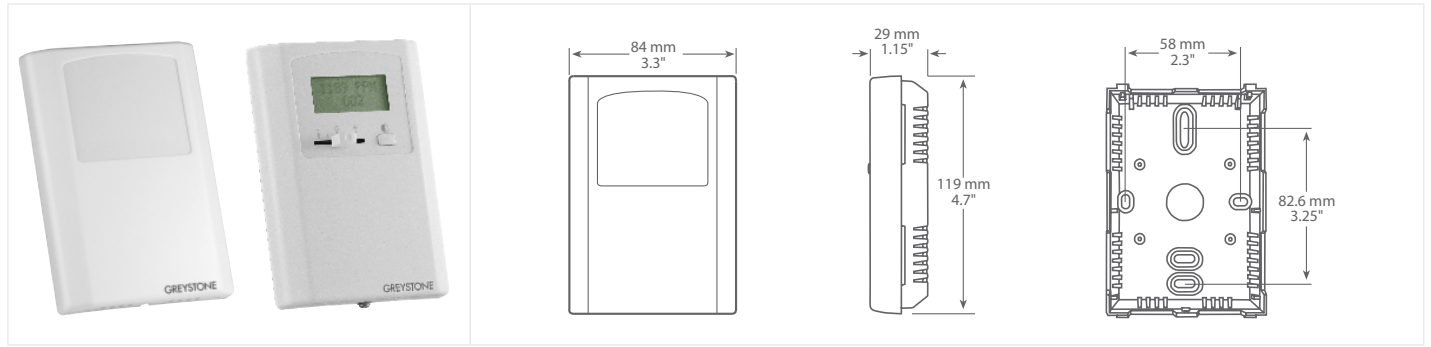

ROOM CARBON DIOXIDE DETECTOR



CDD5 SERIES

PRODUCT DESCRIPTION

The CDD5*10 series uses a highly accurate and reliable Non-dispersive Infrared (NDIR) sensor to monitor CO₂, a precision thermistor to monitor temperature and a thermoset polymer based capacitance sensor to measure humidity levels combined with state-of-the-art digital linearization and temperature compensated circuitry in an attractive, low profile enclosure for room applications and provides 3 analog outputs. Optional setpoint slidepot, momentary override and adjustable relay output are also available.

TYPICAL INSTALLATION

For complete installation and wiring details, please refer to the product installation instructions.

The CDD5 series can be mounted directly to a single gang electrical box or directly to a wall. The backplate includes many mounting hole configurations to allow for mounting on a variety of electrical boxes.

The basic CDD5 has a 5 wire configuration with a screw block terminal provided for connection to the Building Automation System.

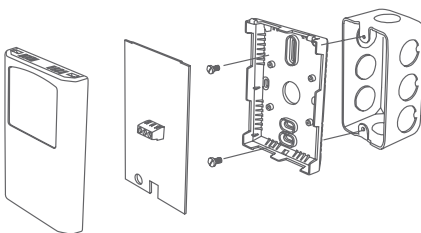

SPECIFICATIONS

CO₂ SIGNAL	<p>Measurement Type: CDD5A & B - Non-Dispersive Infrared (NDIR) CDD5C & D - Dual Channel Non-Dispersive Infrared(NDIR), diffusion sampling</p> <p>Range: CDD5A & B - 0-2000ppm CDD5C & D - 0-20,000ppm standard, programmable span from 2000 to 20,000ppm</p> <p>Standard Accuracy: CDD5A & B - ± 30ppm +3% of reading with Auto Cal on CDD5C & D - ±75ppm or 10% of reading (whichever is greater)</p> <p>Temperature Dependence: 0.2% FS per °C</p> <p>Stability: CDD5A & B - <2% FS over life of sensor (15 years typical) CDD5C & D - <5% FS over life of sensor (15 years typical)</p> <p>Pressure Dependence: < 0.13% of reading per mm Hg</p> <p>Altitude Correction: Programmable from 0-5000 ft via keypad</p> <p>Response Time: <2 minutes for 90% step change typical</p> <p>Warm-up Time: <2 minutes</p>
TEMPERATURE SIGNAL	<p>Sensing Element: Precision thermistor</p> <p>Range: 0 to 35°C (32 to 95°F) or 0 to 50°C (32 to 122°F) selectable via keypad</p>
RH SIGNAL	<p>Sensing Element: Thermoset polymer based capacitive</p> <p>Accuracy: ±2 %RH</p> <p>Range: 0 to 100 %RH, non-condensing</p> <p>Hysteresis: ±3 %RH</p> <p>Response Time: 15 seconds typical</p> <p>Stability: ±1.2 %RH typical @ 50 %RH in 5 years</p>
OPTIONAL RELAY OUTPUT	<p>Contact Ratings: Form A contact (N.O.), 2 Amps @ 140 Vac/30 Vdc</p> <p>Relay Trip Point: CDD5A & B - Programmable 500 - 2000ppm via keypad CDD5C & D - Programmable 500-15,000ppm via keypad</p> <p>Relay Hysteresis: CDD5A & B - Programmable 25-200ppm via keypad CDD5C & D - Programmable 25-500ppm via keypad</p>
OPTIONAL LCD DISPLAY	<p>Resolution: 1ppm CO₂, 1 %RH, 1°C (1°F)</p> <p>Size: 35mm W x 15mm H (1.4" x 0.6") alpha-numeric 2 line x 8 character</p> <p>Backlight: Enable or disable via keypad</p>
OPTIONAL OVERRIDE SWITCH	Front panel push-button available as two-wire dry-contact output
OPTIONAL SETPOINT CONTROL	Front panel push-buttons available as two-wire resistive output, 0-10 KΩ standard
POWER SUPPLY	20-28 Vdc/ac (non-isolated half-wave rectified)
OUTPUT SIGNALS	<p>Current: 4-20 mA (Model CDD5A & C)</p> <p>Voltage: 0-5 Vdc or 0-10 Vdc (Model CDD5B & D)</p>
CONSUMPTIONS	<p>Current: 145 mA max @ 24 Vdc, 260 mA max @ 24 Vac (with all options)</p> <p>Voltage: 85 mA max @ 24 Vdc, 150 mA max @ 24 Vac (with all options)</p>
OUTPUT DRIVE CAPABILITY	<p>Current: 550Ω max</p> <p>Voltage: 10 KΩ min</p>
OUTPUT RESOLUTION	10 bit PWM
PROTECTION CIRCUITRY	Reverse voltage and output limited
OPERATING CONDITIONS	0 to 50°C (32 to 122°F), 5 to 95 %RH non-condensing
SENSOR COVERAGE AREA	100m ² (1000ft ²) typical
WIRING CONNECTIONS	Screw terminal block (14 to 22 AWG)
ENCLOSURE	White ABS, 84mm W x 119mm H x 29mm D (3.3" x 4.7" x 1.15"), IP30 (NEMA 1)
COUNTRY OF ORIGIN	Canada



WIRING INFORMATION

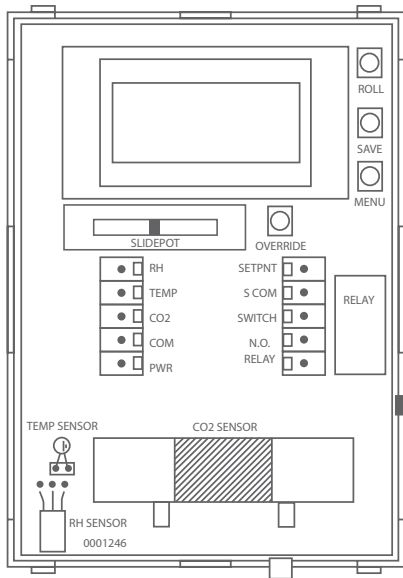

TERMINAL	FUNCTION
RH	Analog Output
TEMP	Analog Output
CO ₂	Analog Output
COM	Common
PWR	24 Vdc Power
SETPNT	Resistive Output
S COM	Common
SWITCH	Digital Output
N.O.	24 Vdc Power
RELAY	Digital Output

ORDERING

PRODUCT	CDD5A10	Room Carbon Dioxide Detector, 0-2000ppm, Temp. & Humidity, 4-20 mA
	CDD5B10	Room Carbon Dioxide Detector, 0-2000ppm, Temp. & Humidity, 0-5 or 0-10 Vdc
	CDD5C10	Room Carbon Dioxide Detector, 0-20,000ppm, Temp. & Humidity, 4-20 mA
	CDD5D10	Room Carbon Dioxide Detector, 0-20,000ppm, Temp. & Humidity, 0-5 or 0-10 Vdc
DISPLAY	0	Concealed
	1	Viewable
OPTIONS (MULTIPLE SELECTIONS CAN BE MADE) (LEAVE BLANK IF NO OPTIONS REQUIRED)	P	Setpoint control, 2 button up/down
	S	Exposed push button momentary switch - N.O.
	R	Relay output

PART NUMBER

NOTE: Greystone Energy Systems, Inc. reserves the right to make design modifications without prior notice.

5-YEAR CALIBRATION GUARANTEE

Based on the results of years of testing of ACLP software, Greystone now offers a 5-year calibration guarantee on all its CDD series wall and duct mount sensors used for CO₂ based ventilation control when operated in an environment that can utilize ACLP software. If the sensor is found to be out of calibration more than 150 PPM as compared to a calibration gas or recently calibrated reference, Greystone will provide a free factory calibration of the sensor if returned to Greystone. This guarantee only applies if the sensor is operated in an environment where inside levels periodically drop to outside concentrations (i.e. during evenings or weekends when there is no occupancy) as is required by ACLP software. If a space does not experience a periodic drop to outside levels (i.e. where occupancy is 24 hours, 7 days/week) a dual sensor channel should be selected.